

Installation Basics

for Solar Domestic Water Heating Systems

Chuck Marken & Ken Olson

©2003 Chuck Marken & Ken Olson

Planning to install a solar domestic hot water (SDHW) system? You'll need some basic plumbing, electrical, mechanical, and carpentry skills. Theories and concepts are good background for any work, but putting a wrench, saw, torch, or other tool on the parts is what gets the job accomplished.

This is part of a series of articles on the installation of solar water heaters. This article covers topics that are applicable to most solar heating installations—collector orientation and mounting, plumbing, and controls. What parts go where, how they are installed and integrated, and complete “nuts and bolts” procedures are the topics for this issue.

Other articles in the series will address the specifics of installation, troubleshooting, repair, and maintenance of

both closed loop antifreeze and drainback systems. Articles in *HP85* and *HP86* left off with the component descriptions and functions, and that's where we will begin.

Collector Tilt, Orientation, & Access

We recommend that solar collectors used for year-round domestic hot water face true south and be tilted up from the horizontal at an angle equal to the latitude of the site plus 15 degrees. For example, for Denver, Colorado, 40 degrees latitude plus 15 degrees equals 55 degrees from horizontal. A south-facing surface tilted at an angle equal to latitude will actually collect maximum sunlight year-round. Where aesthetics are a factor, many people choose to mount collectors at the roof angle.

Variations 20 degrees either way will not seriously affect the total annual output (about 5%), but will create some seasonal imbalances. Tilting your collectors up to latitude plus 15 degrees will give you fewer overheating problems in the summer and more hot water in the winter. You should keep in mind that SDHW systems

tend to overproduce in the summer, and any tilt angle less than the recommended optimum will produce even more in the summer. The loss with a lower tilt angle will be in the winter months when the systems tend to produce the least.

Ideally, your collector orientation should be exactly true south if you have an unobstructed solar window. Fortunately, solar hot water systems are surprisingly forgiving as far as orientation. Orientations 15 degrees off true south still capture 90 percent of total daily sunshine. Orientations up to 30 degrees off true south are acceptable, but may lose as much as 20 percent of optimum sunshine. You can increase your collector size to compensate for a less than ideal orientation.

If you have a choice of facing the collectors more easterly or westerly because the home's orientation prevents a due south installation, choose the west for slightly increased performance. The afternoon has higher ambient temperatures. Prevailing cloudiness that exists in some locations may also have a bearing on the orientation of your collectors. Locations with morning clouds will have better performance if collectors are faced in a more westerly direction, and easterly works better for prevailing afternoon clouds.

Your compass lies. It points to magnetic south. In some parts of the U.S., true south can be as much as 22 degrees east or west of magnetic south. To find true south, you need to adjust for the magnetic declination of your site. In Denver, Colorado, the magnetic declination is 14 degrees east. This means that true south is really 14 degrees east of magnetic south or a compass reading of 166 degrees. Refer to the accompanying map for magnetic declination for the U.S. See Access for additional info on magnetic declination.

Magnetic Declination

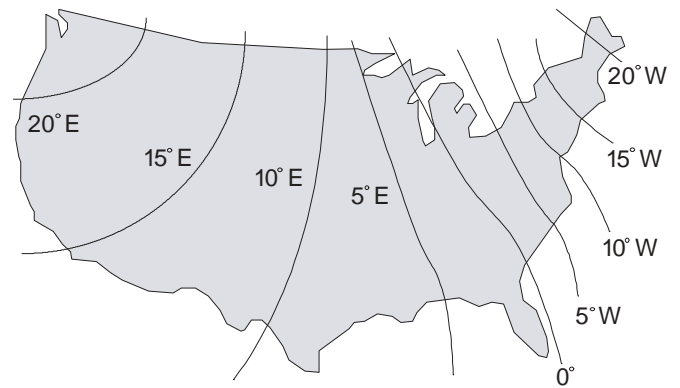

Solar collectors don't work well in the shade. Collectors should be totally unshaded from 9 AM to 3 PM standard time, year-round. Avoid shading earlier and later in the day if you can. Many professional installers use a Solar Pathfinder when they need to evaluate shading. (See *HP16*, and the video clip on Solar1 CD.) One glance into the Pathfinder and you can see all the shading your collectors will get all day and all year. A sun path chart can also be used—see Access for info.

Mounting Solar Collectors

Solar collectors used for heating domestic hot water (DHW) are usually mounted on roofs, where there is often plenty of unused space. Shading from trees and buildings is usually less of a problem on roofs. Mounting hardware can be supplied by the collector manufacturer or you can build it yourself.

Factory mounting hardware typically comes in two types—flush or rack mounted. Flush mounts (also called stand-off mounts) are used to mount the collectors at the



Flush-mounted system.



Homemade ground-mount rack.



Ground-mounted commercial system.



Rack-mounted, PV powered system.

same pitch as the roof. A rack mount has precut or adjustable legs to tilt the collector at an angle to the roof.

Manufactured collectors often have a proprietary extruded aluminum frame incorporating a ready-made channel or other feature to attach the mounting structure with a screw, bolt, or proprietary fastener supplied by the manufacturer. If the mounts are connected to the collector with heavy, self-tapping screws, care should be taken that the screws don't penetrate any farther than necessary, to avoid contact with collector piping or glass.

Roof Mounting Details

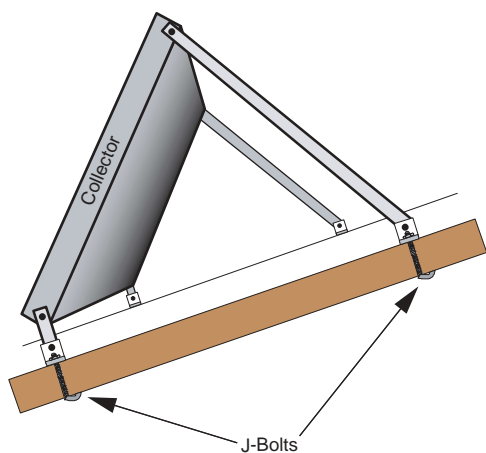

A J-bolt can be made with all-thread rod and wrapped around the roof's structural members.

Whether the rack is homemade or manufactured, painted angle iron can be used for mounts in areas of low humidity. Aluminum angle is preferred where steel and iron are subject to heavy rust over long periods of time. Stainless steel mounting hardware is often used in humid, rainy, or coastal climates. Be sure to choose sturdy enough sizes to support the weight, and in some communities, engineering will be required.

Many homeowner installations use treated lumber. This can provide an adequate collector mount system, but maintenance of the wood is a drawback. Although the treated wood may last for up to a few decades, screwed connections are prone to weaken over time. Through-bolts should be used for all connections to treated wood.

An important consideration to keep in mind regarding all types of roof mounting is that the mount hardware must be fastened directly to the structural members of the roof—the joists, rafters, or trusses. Screwing the collectors to the roof sheathing will not last in a heavy wind or over time. Some local codes require that collectors be J-bolted to the structural members. A J-bolt

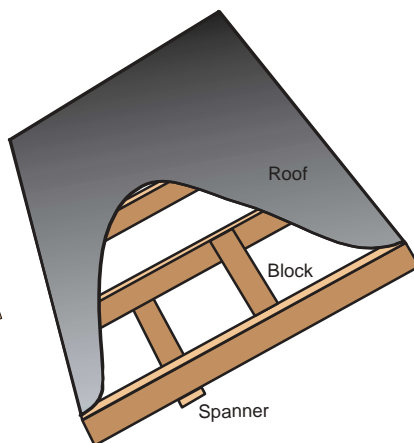

Spanners (2 x 4 or 6 lumber or steel angle) go under the roof joists and are bolted through the roof to the collector mounts. Blocking is lumber that is nailed between the joists against the bottom of the roof, and lag screws are used to secure the collector mounts to them.

wraps around the structural member and is then bolted to the mount. This requirement is not the norm, but is based on concern about lag screws weakening the structural members.

Another method of securing the mounts is with a spanner block placed under or between two structural members in the attic. Long bolts or all-thread are run through the roof and bolted to the mounts. This works well when you have access under the roof.

Lag screws, if used, should be at least 1/4 inch (6 mm) diameter. Minimum length is 3 to 4 inches (7–10 cm) for a normal composition shingle roof with 1/2 to 3/4 inch (13–19 mm) decking. At least 2 inches (5 cm) penetration into the joist or truss is required. Wood shake roofs will require 4 or 5 inch (10 or 13 cm) lag screws. Care must be taken to make sure the lag screws are placed in the center of the structural members. It is often difficult to locate the exact center of 1 1/2 inch rafters.

Cement and clay tile roofs will need to be cut and flashed, and the mounts will be right above the roofing felt under the tiles. The exact attachment details can be rather involved for each type of roof, and are not within the scope of this article.

Roof Penetrations

Roof penetrations will normally need to be made for collector piping and collector mounts. The wires needed for the collector sensor can be run alongside one or both of the insulated pipes to the collectors. Roof penetrations for piping need to be slightly larger than the diameter of the piping and its insulation. A 2 inch (5 cm) diameter hole is usually all that is required for a single pipe. A 3 to 4 inch (7–10 cm) hole may be required for two pipes.

Using one penetration for each pipe is neater, easier to seal, and exposes less piping to the elements. You

Roof Jack and Roof Mount Lag Screw Detail

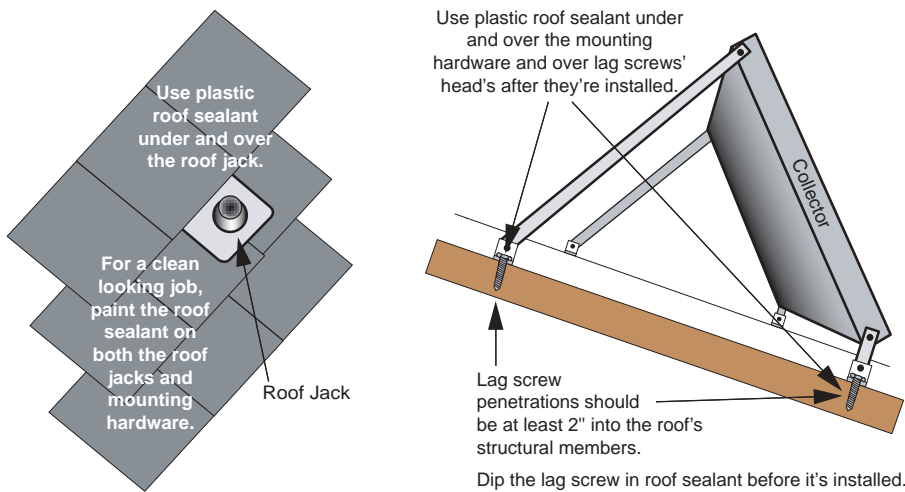

should avoid contact between the pipe and roof structure, since this can cause damage to the pipes over time. Plastic pipe insulators are handy devices for running a pipe through any roof sheathing or structural member. They hold the pipe to avoid movement, which may cause wear and tear, or stress the weatherproof seal.

A roof jack is required for all pipe penetrations. A roof jack is a formed, sheet metal component with a flat bottom and an attached metal or rubber cone-shaped projection that has an opening for pipe, duct, or conduit. The flat portion can be slid under shingles and nailed or screwed to the roof. The cone projection prevents rain and snow from entering the attic or roof space.

The hole in the roof should be placed so that the flat part of the roof jack will slide under an existing shingle above, and over the existing shingles below. Coat the top of the fastener with a generous dollop of roof sealant. If you are penetrating a metal roof, you should use the roof jacks provided by the manufacturer of the roofing material.

Sealing the mount screws or bolts and the part of the mounts that are directly in contact with the roof surface can be done with roof sealant. Contractor's silicone caulking is good for metal or other nonporous surfaces. All of these products, and roof jacks of various sizes and types are available at home centers and plumbing supply houses.

Ground Installation

Pipe distance to and from the collector is often an issue with ground installations. Lengths of up to 50 feet (15 m) are generally acceptable if the piping is well insulated. If the piping is underground, it and its insulation should be encased in a larger PVC pipe.

The classic ground installation uses a very simple "pier" of concrete to secure the collectors to the ground. You can make the piers by digging holes with a post-hole digger and pouring ready-mix concrete. Small installations of one to three collectors will require four piers, which must extend below the ground frost level for your area.

When the concrete is poured, you should embed an anchor bolt or a 6 to 12 inch (15–30 cm) piece of angle iron or aluminum angle. This is used to fasten the collector mounts after the concrete has had time to cure. A string or torpedo level should be used to level the tops of all piers and

anchor bolts for easier installation and a professional appearance.

Wall Mount Installation

Factory or site-built mounts can be easily adapted for mounting collectors to the side of a home or other building. This is an often forgotten option that can work very well if the home is oriented with a suitable unshaded southern wall. Sealing the roof is no longer a concern, and the extra work of a ground mount is eliminated.

On many two-story homes, there is enough space on the second story wall to install a collector or two without conflict with any windows. If this is an option for you, it is probably the easiest installation from the standpoint of work location and collector mounting. The mounts should be lag screwed or bolted directly to the center of the wall studs rather than just the wall sheathing. Be sure to use a sturdy enough fastening technique to handle the shear weight of the collector and water.

Collector Piping

Copper is the favored material for collector piping. SDHW systems can get very hot at certain times of the

Concrete Pier

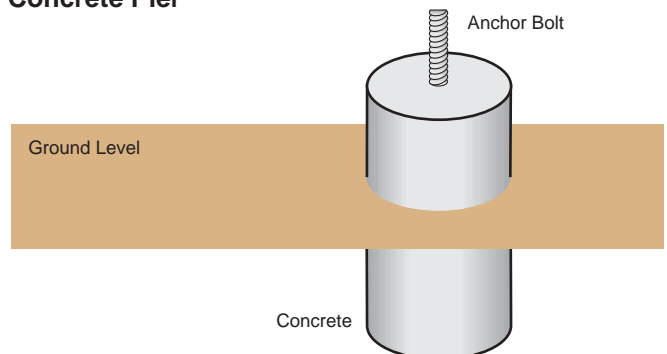

Reverse Return SDHW Piping

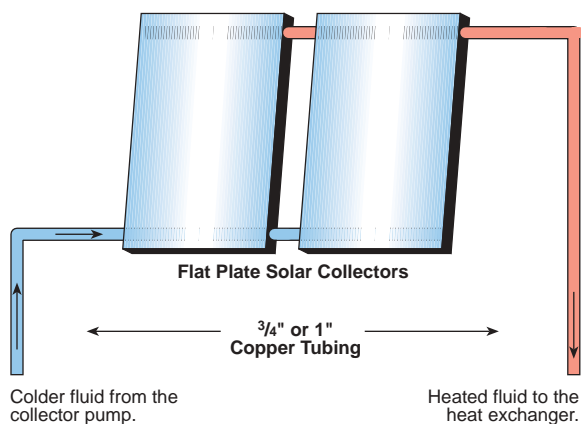

High temperature black insulation should be used on collector piping; gray insulation is OK for standard piping.

year, and copper will take all the heat a system can produce. Chlorinated polyvinyl chloride (CPVC) piping is sometimes used for passive water heaters. Closed loop systems can exceed the temperature and pressure limitations of CPVC. Other types of plastic piping with high temperature limits in the 200°F (93°C) range are also unsuitable for closed loop systems. The exceptions are silicone tubing and Teflon tubing. However, both of these have special connections and components that you won't find at home centers.

The collector supply pipe is always connected from the pump to the cold inlet at one end of the bottom header pipe of the collector. The return pipe runs from the hot outlet of the collector(s) and runs to the heat exchanger next to the storage tank. The hot collector outlet is always at the end of the top header that is diagonally opposite and farthest away from the cold inlet at the end of the bottom header. This piping arrangement is called "reverse return," and will give an even flow through the collector(s).

Hard copper pipe is available in lengths up to 20 feet (6 m) and can be cut with an inexpensive pipe cutter. Type M copper with a red stripe along the length is all that is normally required for residential plumbing. Pipe size is typically 3/4 inch for smaller systems and 1 inch for larger systems. Type L soft copper is rarely used, but may be handy if a flexible pipe is needed to make up for poor alignment of pipes.

Exposed Pipe Insulation

All pipe insulation exposed to ultraviolet (UV) rays of the sun needs protection for long-term durability. A good UV-resistant paint will last from five to ten years, and manufacturers

of high-temperature, closed-cell insulation have recommended products.

If you want a maintenance-free covering for the insulation that will last a lifetime, flat, architectural-grade aluminum used for camper shells and gutters is a good solution. It is easily bent around the insulation and can be fastened with very short screws (using proper care), or bent to form a self-fastening clip.

The Control System

Almost all solar water heaters use the same type of electronic control, a differential control (aka differential thermostat), which is described in depth in *HP85*, *HP86*, and in a "What the Heck?" feature in this issue. The differential control is used to control the system if AC pumps are used. The Goldline GL-30 has two temperature sensors. One is located at the outlet (top) of the collector piping. The other is located at the cold DHW piping on the storage tank. This control can be

Some of the tools and parts you might need for soldering copper tubing include solder, flux, Teflon tape, and fittings.



Soldering Copper Pipe

Many people have trouble soldering copper pipe. Follow these five simple steps and you'll have solid, leak-free solder joints, 100 percent of the time.

Use a propane, MAPP gas (methylacetylene-propadiene), or acetylene torch—the temperatures required don't demand an oxygen/acetylene torch. Solder containing lead, better known as 50/50 (50% lead and 50% tin), is not allowed on potable water connections for health safety. Lead-free solder such as 95/5 (95% tin and 5% antimony) is better for solar loop systems because of its higher melting point.

1. Make sure the pipe will stay dry during the soldering process. Clean the pipe and fittings with a wire brush or emery cloth. The surface must be bright, fresh copper, free of oxidation.
2. Use a good grade of soldering paste flux. Brush it on the entire surface of cleaned pipe and fittings to chemically clean the surfaces.
3. Apply the heat from the torch to the fitting at the full depth of pipe penetration (underside if possible), not to the pipe.
4. Apply the solder to the pipe on the opposite side from where the heat is applied to the fitting. Dab it onto the pipe a few times after heating the fitting. The solder will flow into and around the joint when the joint is hot enough. Quickly remove the flame from the fitting after the solder melts and completely fills the joint(s).
5. Don't touch or jiggle the pipe or fittings while they are cooling.

When a solder joint is cleaned, fluxed, and at the right temperature, you'll see solder flow into the joint and "disappear" if you watch closely. Failed solder joints are always caused by careless cleaning, poor or no flux, an underheated or overheated joint, or movement of the joint(s) while they are cooling.

On small pipe, $\frac{1}{2}$ to $\frac{3}{4}$ inch, two or more joints can be heated and soldered at once, such as all three sides of a small tee fitting. The larger the pipe, or the heavier the fitting, the longer it takes to heat the joint to proper temperature. Soldering the headers together on the collectors will normally take a little longer than single joints, since the header pipes can be 1 inch or larger. Outdoor temperature and breezes may also affect the time it takes to solder a joint.

Step 1

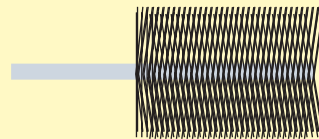
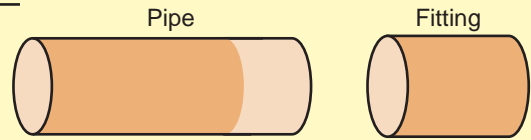

Clean copper pipe and fitting with a wire brush or emery paper until they're both shiny bright.

Step 2

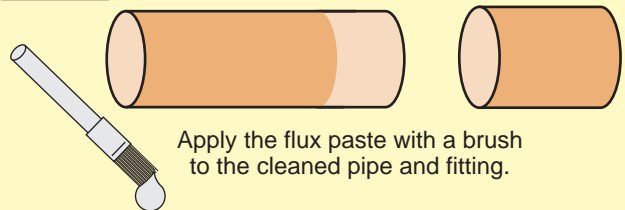

Apply the flux paste with a brush to the cleaned pipe and fitting.

Step 3

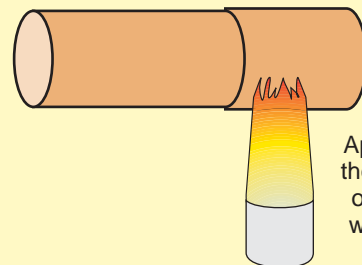

Apply heat to the underside of the fitting with a torch.

Step 4

Apply solder to the pipe opposite to where the heat is being applied to the fitting.

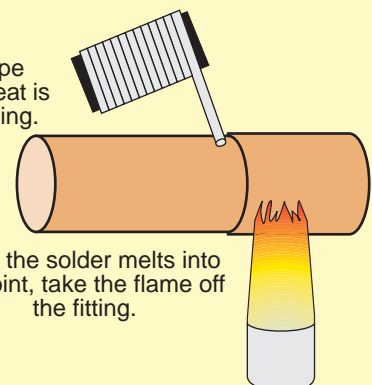

After the solder melts into the joint, take the flame off the fitting.

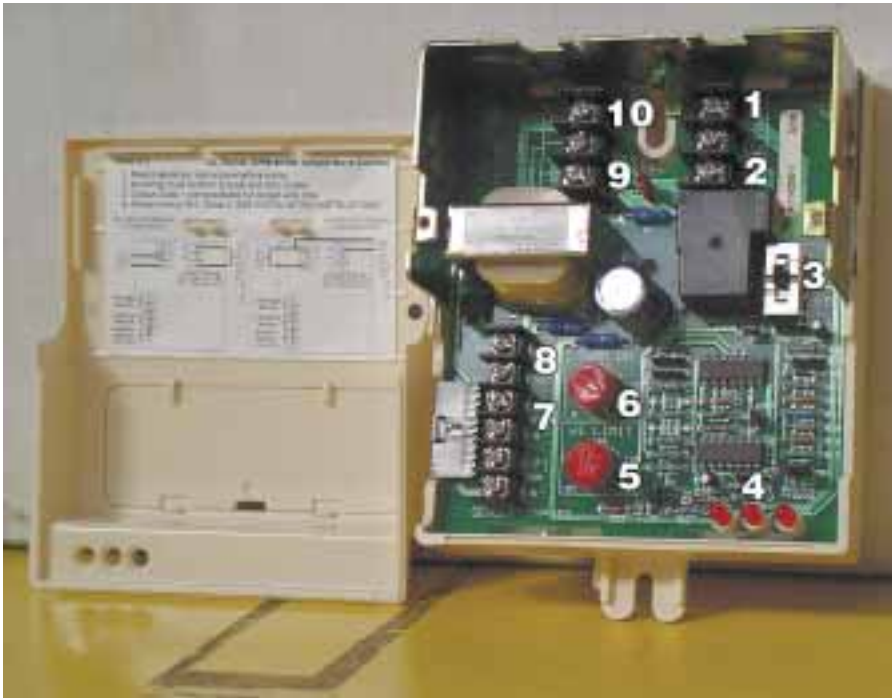

The Goldline GL-30, Differential Control:

1. Terminal for 120 VAC hot (black) wire to collector pump, and DHW pump if used.
2. Terminal for 120 VAC neutral (white) wire to collector pump, and DHW pump if used.
3. On, off, or auto mode switch.
4. LED lights indicate if control is powered, pumping, and/or recirculating.
5. High limit dial.
6. Differential temperature dial.
7. Terminals for collector sensor wires.
8. Terminals for tank sensor wires.
9. Terminal for 120 VAC hot (black) wire.
10. Terminal for 120 VAC neutral (white) wire.

purchased with an existing cord set and receptacle for the pump(s). An alternative control is a Heliotrope Thermal Delta-T.

Thermostat wire (two-conductor, #20 or #22) is used in the sensor control wiring. It is important that the sensors have a good mechanical and thermally conductive connection to the pipe. This is done with a stainless steel, automotive hose clamp on the flat portion of the sensor. Pipe insulation fits over the sensor to correctly read the temperature of the pipe and the liquid flowing in the pipe. Each control has two sets of two terminals for the sensor wiring (four wires total). You must ensure that you correctly attach each sensor to the correct set of terminals. The wiring has no polarity and either wire of each sensor may be correctly attached to either terminal.

The GL-30 control has two small dials to set the control for the correct turn-on temperature and a high-limit temperature. The Delta-T has field selectable DIP (dual in-line package) switches for the same purpose. A recommended turn-on differential temperature for closed loop systems is about 16°F (9°C) for systems with a heat exchanger integrated tank. The turn-off differential temperature is fixed at 4°F (2°C) for the GL-30 and 4 or 5°F (2–3°C) for the Delta-T depending on the DIP switch setting.

The Delta-T DIP switches offer a choice of an 18:5 differential or a 9:4 differential. The higher choice is for closed loop and drainback systems. The lower differentials are for systems without heat exchangers,

and systems used in nonfreezing climates like Hawaii. The exactness of the differential is not critical, because the optimum temperature can vary slightly depending on many factors. Since all closed loop systems incorporate a double-wall heat exchanger, the turn-on for closed loop systems should be more than 12°F (7°C), and generally less than 20°F (11°C). The high temperature limit on the controls is normally set to turn the system off at 180°F (82°C), as recommended by most tank manufacturers.

Both of these controls have a provision for freeze protection in very mild climates. This is a recirculation function that turns the system on as the collector temperature approaches freezing. Freezing is averted by circulating warm water through the collector. This function should be disabled in closed loop and drainback systems. The controls also have a three-position switch (on, auto, off). The switch needs to be in the auto position for the unit to automatically control the pumps with the sun cycle.

A small LED light on the front of the control will tell if the control is powered, and a second light indicates whether the control is running the pump(s). The GL-30 also has a third light to indicate if the recirculation function is on. This light should never be on in a closed loop system if the recirculation function has been disabled. The GL-30 normally ships with the recirculation disabled, but it is a good idea to check this with either control when installing any system in a climate subject to freezing.

The control is usually placed near the pumps that it controls, and this placement is somewhat dependent on

the exact type of system you are installing. Both controls discussed here come with good instructions detailing all of the above features.

PV Powered DC Pumps

It would seem that if there were enough sunlight for a PV module to power a pump, there would be enough sunlight to make hot water. There is *most of the time*. In reality, a PV pump will, at times, turn on before there is sufficient sunlight to make hot water and turn off long after the stored water is already as hot as the collector can produce. This inefficiency due to mismatch between electrical and thermal power can be minimized by using the pump manufacturer's recommended PV module size.

An SDHW, DC pumped system will require a dedicated PV module that is not connected to batteries unless you can find or are capable of building a DC powered differential control. Linear current boosters that add to the efficiency of other PV pumping systems should not be used on dedicated, PV powered SDHW systems. They increase the inefficient mismatching of the thermal energy available to electrical power produced. If you have a whole-house PV system with a large enough inverter, you should consider using less costly AC pumps and a differential control.

The choices of DC hot water circulating pumps are much more limited than AC pumps, and this also could be a consideration. DC pump flow rates and head are dependent on the power output of the PV module(s). AC pumps are much more tolerant of air in the system than DC pumps. A few small bubbles that mean nothing to a higher power AC pump can stop the circulation of some DC pumps.

Skills to Use

We hope these skills and the familiarity with the collector mounting options, plumbing, and control wiring have prepared you for the more detailed topics of the installation and repair of different systems. Our next article will cover what is considered the most complex of SDHW systems—the closed loop, antifreeze-type system. After that will be a repair and maintenance article on the same system, followed by the installation of the simpler, drainback solar water heating system.

Access

Chuck Marken, AAA Solar Supply Inc., 2021 Zearing NW, Albuquerque, NM 87104 • 800-245-0311 or 505-243-4900 • Fax: 505-243-0885 • info@aaasolar.com www.aaasolar.com

Ken Olson, SoL Energy, PO Box 217, Carbondale, CO 81623 • Phone/Fax: 720-489-3798 • sol@solenergy.org www.solenergy.org

Goldline Controls, Inc., 42 Ladd St., East Greenwich, RI 02818 • 800-294-4225 or 401-884-6990

Fax: 401-885-1500 • sales@goldlinecontrols.com www.goldlinecontrols.com • Differential controls

Heliotrope Thermal, 4910 Seaport Ave., Richmond, CA 94804 • 510-237-9614 • Fax: 510-237-7018

info@heliotropethermal.com www.heliotropethermal.com • Differential controls

Solar Pathfinder, 3680 Highway 438, Centerville, TN 37033 • Phone/Fax: 931-593-3552 • Cell: 931-242-0658 pathfind@mlec.net • www.solarpathfinder.com

To find your local magnetic declination see this Florida State Univ. site:

www.gly.fsu.edu/~kish/field/projects/p4/proj4b.htm

To generate a sun chart for your latitude see this University of Oregon site:

http://solardata.uoregon.edu/SunChartProgram.html

See also "Solar Hot Water: A Primer" in *HP84*, "Solar Hot Water for Cold Climates—Closed Loop Antifreeze Systems," in *HP85*, and "Solar Hot Water for Cold Climates—Drainback Systems" in *HP86*.



Snorkel Wood-Fired Hot Tubs

Real WOOD HOT TUB

HALF THE COST

of Plastic Spas!



LOW-COST WOOD HEAT!

Gas/electric heaters, hydrotherapy jets optional!

10 Models! Made in USA!



Made in USA!

Mail this coupon or CALL TOLL FREE

1-800-962-6208

YES! Rush me facts on SNORKEL Wood-Fired Hot Tubs including current SALE!

Name _____

Address _____

City/State/Zip _____

Snorkel Wood-Fired Hot Tubs
Dept. HP034-A, 4216 6th Ave. South, Seattle, WA 98108
www.snorkel.com

FREE SALE CATALOG!



- Utterly **RELAXING** – Practical, pleasurable way to unwind
- **100% WOOD Tub** – Naturally beautiful Western Red Cedar
- **UNDERWATER Wood Stove** – Ingenious, high-efficiency
- **Super AFFORDABLE** – Starting under \$1,900, pennies to heat
- **NO Electric, NO Plumbing** – Hassle-free enjoyment ANYWHERE