

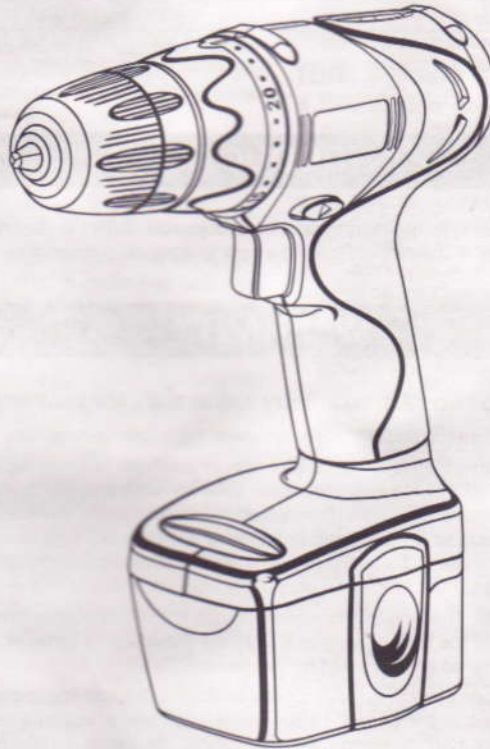

OPERATOR'S MANUAL CORDLESS DRILL-DRIVER

HP496 – 9.6 V

HP412 – 12 V



Your cordless drill-driver has been engineered and manufactured to our high standard for dependability, ease of operation, and operator safety. When properly cared for, it will give you years of rugged, trouble-free performance.



WARNING: To reduce the risk of injury, the user must read and understand the operator's manual before using this product.

Thank you for your purchase.

SAVE THIS MANUAL FOR FUTURE REFERENCE

TABLE OF CONTENTS

■ Introduction	2
■ Warranty	2
■ General Safety Rules	3-4
■ Specific Safety Rules	4
■ Safety Rules for Charger	5
■ Symbols	6-7
■ Features	8-9
■ Assembly	10
■ Operation	11-15
■ Maintenance	17-18
■ Parts Ordering / Service	20

INTRODUCTION

This tool has many features for making its use more pleasant and enjoyable. Safety, performance, and dependability have been given top priority in the design of this product making it easy to maintain and operate.

WARRANTY

RYOBI® POWER TOOL - LIMITED TWO YEAR WARRANTY AND 30 DAY EXCHANGE POLICY

One World Technologies, Inc., warrants its RYOBI® power tools with the following conditions:

30-DAY EXCHANGE POLICY: During the first 30 days after date of purchase, you may either request service under this warranty or you may exchange any RYOBI® power tool which does not work properly due to defective workmanship or materials by returning the power tool to the dealer from which it was purchased. To receive a replacement power tool or requested warranty service, you must present proof of purchase and return all original equipment packaged with the original product. The replacement power tool will be covered by the limited warranty for the balance of the two year period from the date of the original purchase.

WHAT THIS WARRANTY COVERS: This warranty covers all defects in workmanship or materials in your RYOBI® power tool for a period of two years from the date of purchase. With the exception of batteries, power tool accessories are warranted for ninety (90) days. Batteries are warranted for two years.

HOW TO GET SERVICE: Just return the power tool, properly packaged and postage prepaid, to an Authorized Service Center. You can obtain the location of the Service Center nearest you by contacting a service representative at One World Technologies, Inc., P.O. Box 1207, Anderson, SC 29622-1207, by calling 1-800-525-2579 or by logging on to www.ryobitools.com. When you request warranty service, you must also present proof of purchase documentation, which includes the date of purchase (for example, a bill of sale). We will repair any faulty workmanship, and either repair or replace any defective part, at our option. We will do so without any charge to you. We will complete the work in a reasonable time, but, in any case, within ninety (90) days or less.

WHAT'S NOT COVERED: This warranty applies only to the original purchaser at retail and may not be transferred. This warranty only covers defects arising under normal usage and does not cover any malfunction, failure or defects resulting from misuse, abuse, neglect, alteration, modification or repairs by other than Authorized Service Centers. One World Technologies, Inc. makes no warranties, representations or promises as to the quality or performance of its power tools other than those specifically stated in this warranty.

ADDITIONAL LIMITATIONS: Any implied warranties granted under state law, including warranties of merchantability or fitness for a particular purpose, are limited to two years from the date of purchase. One World Technologies, Inc. is not responsible for direct, indirect, or incidental damages, so the above limitations and exclusions may not apply to you. This warranty gives you specific legal rights, and you may also have other rights which vary from state to state.

GENERAL SAFETY RULES

WARNING!

READ AND UNDERSTAND ALL INSTRUCTIONS. Failure to follow all instructions listed below, may result in electric shock, fire and/or serious personal injury.

SAVE THESE INSTRUCTIONS

WORK AREA

- **Keep your work area clean and well lit.** Cluttered benches and dark areas invite accidents.
- **Do not operate power tools in explosive atmospheres, such as in the presence of flammable liquids, gases, or dust.** Power tools create sparks which may ignite the dust or fumes.
- **Keep bystanders, children, and visitors away while operating a power tool.** Distractions can cause you to lose control.

ELECTRICAL SAFETY

- **A battery operated tool with integral batteries or a separate battery pack must be recharged only with the specified charger for the battery.** A charger that may be suitable for one type of battery may create a risk of fire when used with another battery.
- **Use battery operated tool only with specifically designated battery pack.** Use of any other batteries may create a risk of fire.
- **Use battery only with charger listed.**

MODEL	BATTERY PACK	CHARGER
HP496	130269002, 130269014	140295002
HP412	130269003, 130269012	140295003

- **Do not abuse the cord.** Never use the cord to carry the charger. Keep cord away from heat, oil, sharp edges, or moving parts. Replace damaged cords immediately. Damaged cords may create a fire.

PERSONAL SAFETY

- **Stay alert, watch what you are doing and use common sense when operating a power tool.** Do not use tool while tired or under the influence of drugs, alcohol, or medication. A moment of inattention while operating power tools may result in serious personal injury.
- **Dress properly.** Do not wear loose clothing or jewelry. Contain long hair. Keep your hair, clothing, and gloves away from moving parts. Loose clothes, jewelry, or long hair can be caught in moving parts.
- **Avoid accidental starting.** Be sure switch is in the locked or off position before inserting battery pack. Carrying tools with your finger on the switch or inserting the battery pack into a tool with the switch on invites accidents.
- **Remove adjusting keys or wrenches before turning the tool on.** A wrench or a key that is left attached to a rotating part of the tool may result in personal injury.

- **Do not overreach.** Keep proper footing and balance at all times. Proper footing and balance enable better control of the tool in unexpected situations.
- **Use safety equipment.** Always wear eye protection. Dust mask, non-skid safety shoes, hard hat, or hearing protection must be used for appropriate conditions.
- **Do not wear loose clothing or jewelry.** Contain long hair. Loose clothes, jewelry, or long hair can be drawn into air vents.
- **Do not use on a ladder or unstable support.** Stable footing on a solid surface enables better control of the tool in unexpected situations.

TOOL USE AND CARE

- **Use clamps or other practical way to secure and support the workpiece to a stable platform.** Holding the work by hand or against your body is unstable and may lead to loss of control.
- **Do not force tool.** Use the correct tool for your application. The correct tool will do the job better and safer at the rate for which it is designed.
- **Do not use tool if switch does not turn it on or off.** A tool that cannot be controlled with the switch is dangerous and must be repaired.
- **Disconnect battery pack from tool or place the switch in the locked or off position before making any adjustments, changing accessories, or storing the tool.** Such preventive safety measures reduce the risk of starting the tool accidentally.
- **Store idle tools out of reach of children and other untrained persons.** Tools are dangerous in the hands of untrained users.
- **When battery pack is not in use, keep it away from other metal objects like: paper clips, coins, keys, nails, screws, or other small metal objects that can make a connection from one terminal to another.** Shorting the battery terminals together may cause sparks, burns, or a fire.
- **Maintain tools with care.** Keep cutting tools sharp and clean. Properly maintained tools with sharp cutting edges are less likely to bind and are easier to control.
- **Check for misalignment or binding of moving parts, breakage of parts, and any other condition that may affect the tool's operation.** If damaged, have the tool serviced before using. Many accidents are caused by poorly maintained tools.
- **Use only accessories that are recommended by the manufacturer for your model.** Accessories that may be suitable for one tool may create a risk of injury when used on another tool.
- **Keep the tool and its handle dry, clean and free from oil and grease.** Always use a clean cloth when cleaning. Never use brake fluids, gasoline, petroleum-based products, or any strong solvents to clean your tool. Following this rule will reduce the risk of loss of control and deterioration of the enclosure plastic.

GENERAL SAFETY RULES

SERVICE

- **Tool service must be performed only by qualified repair personnel.** Service or maintenance performed by unqualified personnel may result in a risk of injury.
- **When servicing a tool, use only identical replacement parts. Follow instructions in the Maintenance section of this manual.** Use of unauthorized parts or failure to follow Maintenance Instructions may create a risk of shock or injury.

SPECIFIC SAFETY RULES

- **Hold tool by insulated gripping surfaces when performing an operation where the cutting tool may contact hidden wiring.** Contact with a "live" wire will also make exposed metal parts of the tool "live" and shock the operator.
- **Know your power tool. Read operator's manual carefully. Learn its applications and limitations, as well as the specific potential hazards related to this tool.** Following this rule will reduce the risk of electric shock, fire, or serious injury.
- **Always wear safety glasses with side shields.** Everyday glasses have only impact resistant lenses. They are NOT safety glasses. Following this rule will reduce the risk of eye injury.
- **Protect your lungs. Wear a face or dust mask if the operation is dusty.** Following this rule will reduce the risk of serious personal injury.
- **Protect your hearing. Wear hearing protection during extended periods of operation.** Following this rule will reduce the risk of serious personal injury.
- **Battery tools do not have to be plugged into an electrical outlet; therefore, they are always in operating condition. Be aware of possible hazards when not using your battery tool or when changing accessories.** Following this rule will reduce the risk of electric shock, fire, or serious personal injury.
- **Do not place battery tools or their batteries near fire or heat.** This will reduce the risk of explosion and possibly injury.
- **Never use a battery that has been dropped or received a sharp blow.** A damaged battery is subject to explosion. Properly dispose of a dropped or damaged battery immediately.
- **Batteries vent hydrogen gas and can explode in the presence of a source of ignition, such as a pilot light.** To reduce the risk of serious personal injury, never use any cordless product in the presence of open flame. An exploded battery can propel debris and chemicals. If exposed, flush with water immediately.
- **Do not charge battery tool in a damp or wet location.** Following this rule will reduce the risk of electric shock.
- **For best results, your battery tool should be charged in a location where the temperature is more than 50°F but less than 100°F. Do not store outside or in vehicles.**
- **Under extreme usage or temperature conditions, battery leakage may occur. If liquid comes in contact with your skin, wash immediately with soap and water, then neutralize with lemon juice or vinegar. If liquid gets into your eyes, flush them with clean water for at least 10 minutes, then seek immediate medical attention.** Following this rule will reduce the risk of serious personal injury.
- **If the power supply cord is damaged, it must be replaced only by the manufacturer or by an authorized service center to avoid risk.**
- **Save these instructions.** Refer to them frequently and use them to instruct others who may use this tool. If you loan someone this tool, loan them these instructions also.

SAFETY RULES FOR CHARGER

WARNING!

READ AND UNDERSTAND ALL INSTRUCTIONS. Failure to follow all instructions listed below, may result in electric shock, fire and/or serious personal injury.

- **Before using battery charger**, read all instructions and cautionary markings in this manual, on battery charger, battery, and product using battery to prevent misuse of the products and possible injury or damage.

CAUTION:

To reduce the risk of electric shock or damage to the charger and battery, charge only nickel-cadmium rechargeable batteries as specifically designated on your charger. Other types of batteries may burst, causing personal injury or damage.

- **Do not use charger outdoors or expose to wet or damp conditions.** Water entering charger will increase the risk of electric shock.
- **Use of an attachment not recommended or sold by the battery charger manufacturer may result in a risk of fire, electric shock, or injury to persons.** Following this rule will reduce the risk of electric shock, fire, or serious personal injury.
- **Do not abuse cord or charger.** Never use the cord to carry the charger. Do not pull the charger cord rather than the plug when disconnecting from receptacle. Damage to the cord or charger could occur and create an electric shock hazard. Replace damaged cords immediately.
- **Make sure cord is located so that it will not be stepped on, tripped over, come in contact with sharp edges or moving parts or otherwise subjected to damage or stress.** This will reduce the risk of accidental falls, which could cause injury, and damage to the cord, which could result in electric shock.
- **Keep cord and charger from heat to prevent damage to housing or internal parts.**
- **Do not let gasoline, oils, petroleum-based products, etc. come in contact with plastic parts.** They contain chemicals that can damage, weaken, or destroy plastic.

- **An extension cord should not be used unless absolutely necessary.** Use of improper extension cord could result in a risk of fire and electric shock. If extension cord must be used, make sure:

- a. That pins on plug of extension cord are the same number, size and shape as those of plug on charger.
- b. That extension cord is properly wired and in good electrical condition; and
- c. That wire size is large enough for AC ampere rating of charger as specified below:

Cord Length (Feet)	25'	50'	100'
Cord Size (AWG)	16	16	16

NOTE: AWG = American Wire Gauge

- **Do not operate charger with a damaged cord or plug**, which could cause shorting and electric shock. If damaged, have the charger replaced by an authorized serviceman.
- **Do not operate charger if it has received a sharp blow, been dropped, or otherwise damaged in any way.** Take it to an authorized serviceman for electrical check to determine if the charger is in good working order.
- **Do not disassemble charger.** Take it to an authorized serviceman when service or repair is required. Incorrect reassembly may result in a risk of electric shock or fire.
- **Unplug charger from outlet before attempting any maintenance or cleaning to reduce the risk of electric shock.**
- **Disconnect charger from the power supply when not in use.** This will reduce the risk of electric shock or damage to the charger if metal items should fall into the opening. It also will help prevent damage to the charger during a power surge.
- **Risk of electric shock.** Do not touch uninsulated portion of output connector or uninsulated battery terminal.
- **Save these instructions.** Refer to them frequently and use them to instruct others who may use this tool. If you loan someone this tool, loan them these instructions also to prevent misuse of the product and possible injury.

IMPORTANT SAFETY INSTRUCTIONS

1. SAVE THESE INSTRUCTIONS











This manual contains important safety and operating instructions for battery charger 140295002 and 140295003.

2. **Before using battery charger**, read all instructions and cautionary markings on battery charger, battery, and product using battery.

3. **CAUTION:** To reduce the risk of injury, charge only nickel-cadmium rechargeable batteries. Other types of batteries may burst, causing personal injury or damage.



SYMBOLS

Some of the following symbols may be used on this tool. Please study them and learn their meaning. Proper interpretation of these symbols will allow you to operate the tool better and safer.

SYMBOL	NAME	DESIGNATION/EXPLANATION
V	Volts	Voltage
A	Amperes	Current
Hz	Hertz	Frequency (cycles per second)
W	Watt	Power
min	Minutes	Time
~	Alternating Current	Type of current
—	Direct Current	Type or a characteristic of current
n_0	No Load Speed	Rotational speed, at no load
	Class II Construction	Double-insulated construction
.../min	Per Minute	Revolutions, strokes, surface speed, orbits etc., per minute
	Wet Conditions Alert	Do not expose to rain or use in damp locations.
	Read The Operator's Manual	To reduce the risk of injury, user must read and understand operator's manual before using this product.
	Eye Protection	Always wear safety goggles or safety glasses with side shields and a full face shield when operating this product.
	Safety Alert	Precautions that involve your safety.
	No Hands Symbol	Failure to keep your hands away from the blade will result in serious personal injury.
	No Hands Symbol	Failure to keep your hands away from the blade will result in serious personal injury.
	No Hands Symbol	Failure to keep your hands away from the blade will result in serious personal injury.
	No Hands Symbol	Failure to keep your hands away from the blade will result in serious personal injury.
	Hot Surface	To reduce the risk of injury or damage, avoid contact with any hot surface.

SYMBOLS

The following signal words and meanings are intended to explain the levels of risk associated with this product.

SYMBOL	SIGNAL	MEANING
	DANGER:	Indicates an imminently hazardous situation, which, if not avoided, will result in death or serious injury.
	WARNING:	Indicates a potentially hazardous situation, which, if not avoided, could result in death or serious injury.
	CAUTION:	Indicates a potentially hazardous situation, which, if not avoided, may result in minor or moderate injury.
	CAUTION:	(Without Safety Alert Symbol) Indicates a situation that may result in property damage.

SERVICE

Servicing requires extreme care and knowledge and should be performed only by a qualified service technician. For service we suggest you return the product to your nearest **AUTHORIZED SERVICE CENTER** for repair. When servicing, use only identical replacement parts.

WARNING:

To avoid serious personal injury, do not attempt to use this product until you read thoroughly and understand completely the operator's manual. Save this operator's manual and review frequently for continuing safe operation and instructing others who may use this product.

WARNING:



The operation of any power tool can result in foreign objects being thrown into your eyes, which can result in severe eye damage. Before beginning power tool operation, always wear safety goggles or safety glasses with side shields and a full face shield when needed. We recommend Wide Vision Safety Mask for use over eyeglasses or standard safety glasses with side shields. Always use eye protection which is marked to comply with ANSI Z87.1.

SAVE THESE INSTRUCTIONS



FEATURES

PRODUCT SPECIFICATIONS

Chuck	3/8 in. Keyless
Motor	9.6 V DC
Model HP496.....	12 V DC
Model HP412.....	Variable Speed
Switch.....	
No Load Speed	0-580 r/min. (RPM)
Model HP496.....	0-550 r/min. (RPM)
Model HP412.....	24 Positions
Clutch.....	120 V, 60 Hz, AC only
Charger Input.....	3-6 Hours
Charge Rate	
Torque	Maximum 85 in.lb.
Model HP496.....	Maximum 95 in.lb.
Model HP412.....	

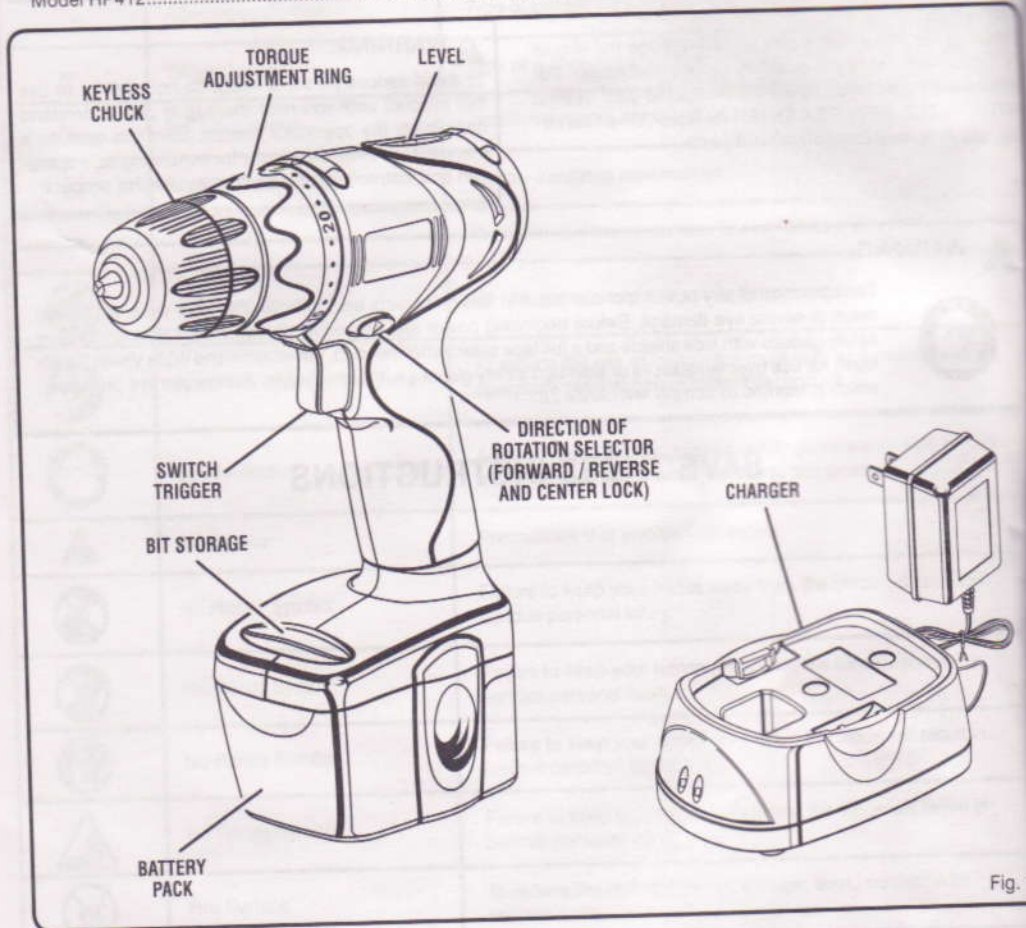

Fig. 1

FEATURES

KNOW YOUR DRILL-DRIVER

See Figure 1.

Before attempting to use this product, familiarize yourself with all operating features and safety rules.

KEYLESS CHUCK

The drill-driver has a keyless chuck that allows you to hand tighten or release drill bit in the chuck jaws.

LEVEL

To keep drill bit level during drilling operations, a level is located on the top end of the motor housing.

SWITCH TRIGGER

The drill-driver has a conveniently located variable speed switch trigger.

SWITCH LOCK

The switch trigger can be locked in the **OFF** position. This feature helps reduce the possibility of accidental starting when not in use.

FORWARD/REVERSE SELECTOR (DIRECTION OF ROTATION SELECTOR)

The drill-driver has a forward/reverse selector located above the switch trigger.

BIT STORAGE

When not in use, bits can be placed in the storage area located on the base of your drill-driver.

CHARGER

Your charger can be used on a flat surface, or it can be mounted on the wall or underneath a counter or shelf for convenient, space-saving storage.

CAUTION

To avoid back injury, do not hold the drill-driver with one hand while using the other hand to operate the trigger. Instead, use both hands to hold the drill-driver. Always use proper lifting techniques. Do not use the drill-driver to lift or move heavy objects. A warning label is located on the side of the drill-driver. For more information, see the manual.

CHARGING THE BATTERY PACK

The battery pack for the drill-driver is recharged in a charging station. To charge the battery pack, insert the battery pack into the charging station. The charging station is located in the manual. Do not use the charging station to charge any other battery pack. The charging station is designed to charge only the battery pack for the drill-driver. Do not use the charging station to charge any other battery pack. The charging station is designed to charge only the battery pack for the drill-driver. Do not use the charging station to charge any other battery pack.



ASSEMBLY

UNPACKING

This product has been shipped completely assembled.

- Carefully remove the tool and any accessories from the box. Make sure that all items listed in the packing list are included.
- Inspect the tool carefully to make sure no breakage or damage occurred during shipping.
- Do not discard the packing material until you have carefully inspected and satisfactorily operated the tool.
- If any parts are damaged or missing, please call 1-800-525-2579 for assistance.

PACKING LIST

- Cordless Drill
- Charger
- Battery Pack (Model HP412 only includes 2)
- Double-ended Bit
- Case
- Operator's Manual

⚠ WARNING:

If any parts are missing do not operate this tool until the missing parts are replaced. Failure to do so could result in possible serious personal injury.

⚠ WARNING:

Do not attempt to modify this tool or create accessories not recommended for use with this tool. Any such alteration or modification is misuse and could result in a hazardous condition leading to possible serious personal injury.

⚠ WARNING:

To prevent accidental starting that could cause serious personal injury, always remove the battery pack from the tool when assembling parts.

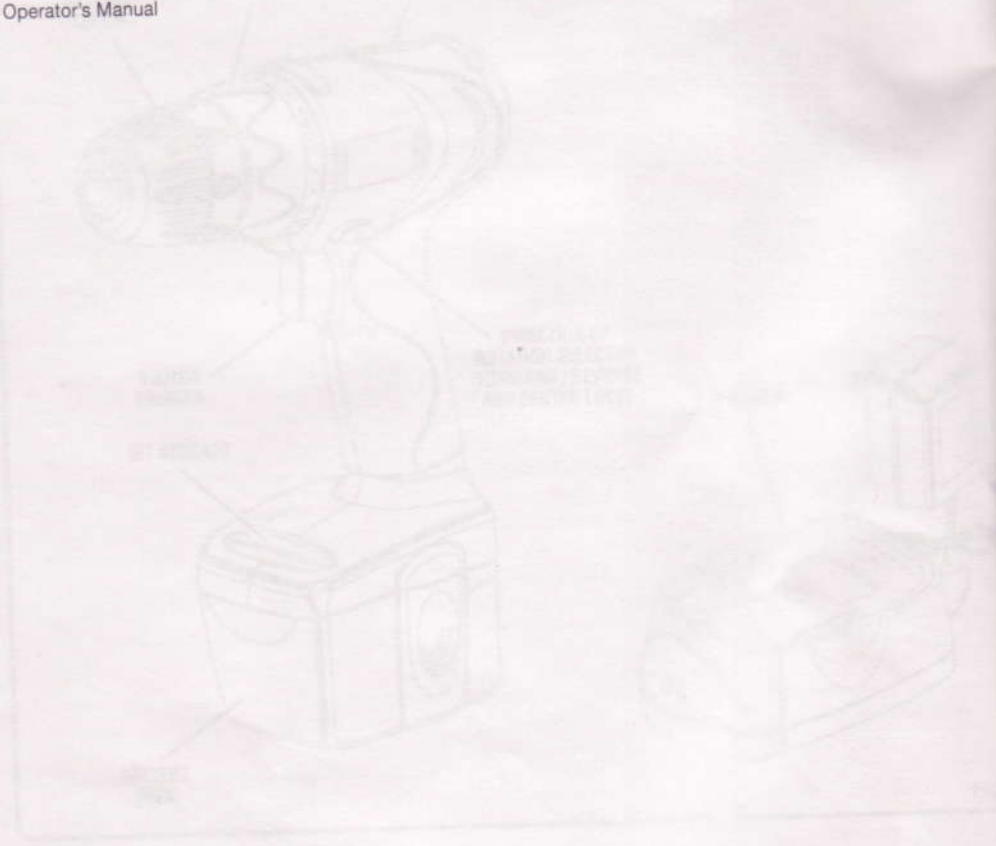

OPERATION

⚠ WARNING:

Do not allow familiarity with tools to make you careless. Remember that a careless fraction of a second is sufficient to inflict serious injury.

⚠ WARNING:

Always wear safety goggles or safety glasses with side shields when operating tools. Failure to do so could result in objects being thrown into your eyes, resulting in possible serious injury.

⚠ WARNING:

Do not use any attachments or accessories not recommended by the manufacturer of this tool. The use of attachments or accessories not recommended can result in serious personal injury.

APPLICATIONS

You may use this tool for the following purposes:

- Drilling in wood
- Drilling in ceramics, plastics, fiberglass, and laminates
- Drilling in both hard and soft metals
- Using driving accessories, such as driving screws with screwdriver bits
- Mixing paints

CAUTION:

To prevent damage to the battery pack, remove the battery pack from the charger immediately if no LED comes on. Return the battery pack and charger to your nearest service center for checking or replacing. Also, if you are removing the battery pack from the charger and no LEDs are on, return both the battery pack and the charger to your nearest service center. Do not insert another battery pack into the charger. A damaged charger may damage a battery pack.

CHARGING THE BATTERY PACK

The battery pack for this tool has been shipped in a low charge condition to prevent possible problems. Therefore, you should charge overnight prior to use.

NOTE: Batteries will not reach full charge the first time they are charged. Allow several cycles (operation followed by recharging) for them to become fully charged.

- Charge battery pack only with the charging assembly provided.
- Make sure power supply is normal household voltage, 120 volts, 60 Hz, AC only.

- Connect charger to power supply.
- Place battery pack in charging stand. Align raised rib on battery pack with groove in charging stand. See Figure 2.
- Press down on battery pack to be sure contacts on battery pack engage properly with contacts in charging stand.
- The charge indicator light (LED), located on the charging stand, will light up red and glow when the charger is properly connected to power supply. This light indicates the charger is operating properly. It will remain on until battery pack is removed from charging stand or charger is disconnected from power supply.
- After normal usage, 3 hours or less of charging time is required to fully recharge battery pack.
- If both red and orange LED indicators glow, the battery pack is deeply or completely discharged, and 6 hours or longer of charging time is required to fully recharge battery pack.

NOTE: If charger does not charge battery pack or orange LED continues to glow after more than 30 minutes of charging, return battery pack and charging assembly to your nearest Ryobi Authorized Service Center for electrical check.

- The battery pack will become slightly warm to the touch while charging. This is normal and does not indicate a problem.
- Do not place charger in an area of extreme heat or cold. It will work best at normal room temperature.
- When batteries become fully charged, unplug charger from power supply and remove the battery pack.

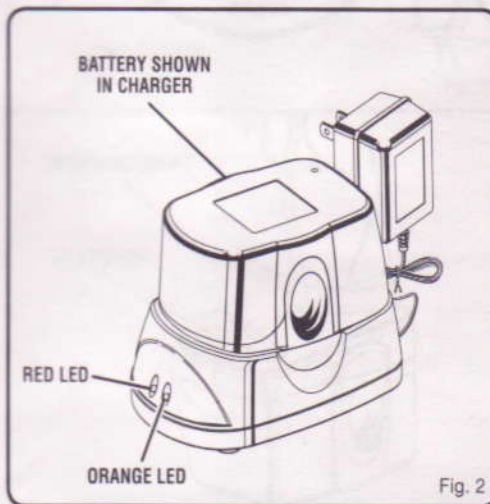

Fig. 2

CHARGING A HOT BATTERY PACK

When using the tool continuously, the batteries in the battery pack will become hot. You should let a hot battery pack cool down for approximately 30 minutes before attempting to recharge.

NOTE: This situation only occurs when continuous use of the drill causes the batteries to become hot. It does not occur under normal circumstances. Refer to "CHARGING THE BATTERY PACK" for normal recharging of batteries. If the charging assembly does not charge the battery pack under normal circumstances, return both the battery pack and charging assembly to your nearest Ryobi Authorized Service Center for electrical check.

TO INSTALL BATTERY PACK

See Figure 3.

- Place the direction of rotation selector in center position.
- Place the battery pack in the drill. Align raised rib on battery pack with groove in drill's battery port.
- Make sure the latches on each side of the battery pack snap in place and that battery pack is secured in drill before beginning operation.

TO REMOVE BATTERY PACK

- Place the direction of rotation selector in center position.
- Locate latches on side of battery pack and depress both sides to release battery pack from the drill.
- Remove battery pack from the drill.

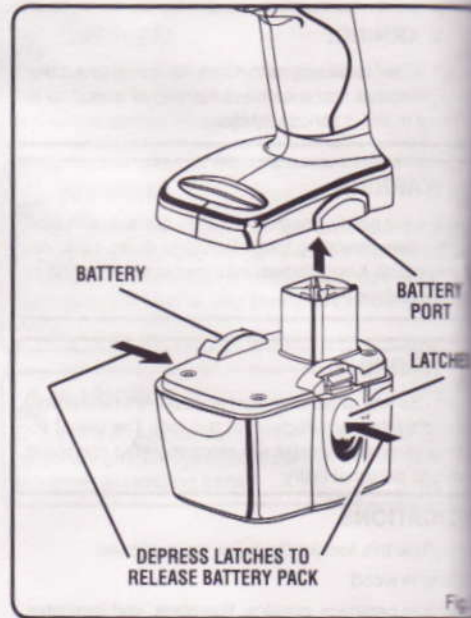

INSTALLING BITS

See Figures 4 - 5.

- Lock the switch trigger by placing the direction of rotation selector in center position.
 - Open or close chuck jaws to a point where the opening is slightly larger than the bit size you intend to use. Also, raise the front of the drill slightly to keep the bit from falling out of the chuck jaws.
 - Insert drill bit straight into chuck the full length of the jaws.
 - Tighten the chuck jaws on the drill bit.
 - To tighten: grasp and hold the collar of the chuck with one hand, while rotating the chuck body with your other hand.
- NOTE:** Rotate the chuck body in the direction of the arrow marked **LOCK** to tighten chuck jaws.
- **Do not** use a wrench to tighten or loosen the chuck jaws.

⚠ WARNING:

Make sure to insert the drill bit straight into the chuck jaws. Do not insert the drill bit into the chuck jaws at an angle then tighten, as shown in figure 5. This could cause the drill bit to be thrown from the drill, resulting in possible serious personal injury or damage to the chuck.

REMOVING BITS

See Figure 4.

- Lock the switch trigger by placing the direction of rotation selector in center position.
 - Loosen the chuck jaws from the drill bit.
 - To loosen: grasp and hold the collar of the chuck with one hand, while rotating chuck body with your other hand.
- NOTE:** Rotate chuck body in the direction of the arrow marked **UNLOCK** to loosen chuck jaws.
- **Do not** use a wrench to tighten or loosen the chuck jaws.
 - Remove the drill bit from the chuck jaws.
- NOTE:** Rotate the chuck body in the direction of the arrow marked **GRIP** to tighten the chuck jaws. **DO NOT** use a wrench to tighten or loosen the chuck jaws.

BIT STORAGE

See Figure 6.

When not in use, bits provided with the drill can be placed in the storage area located on the base of the drill.

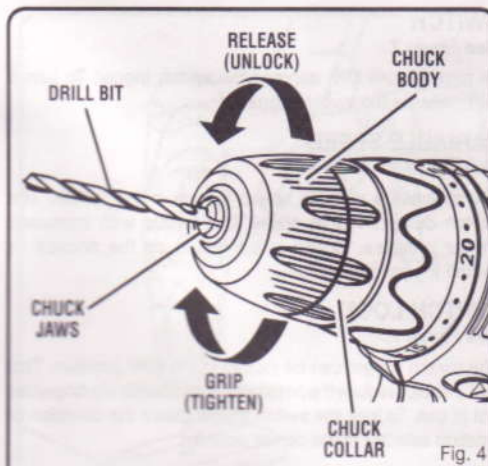

Fig. 4

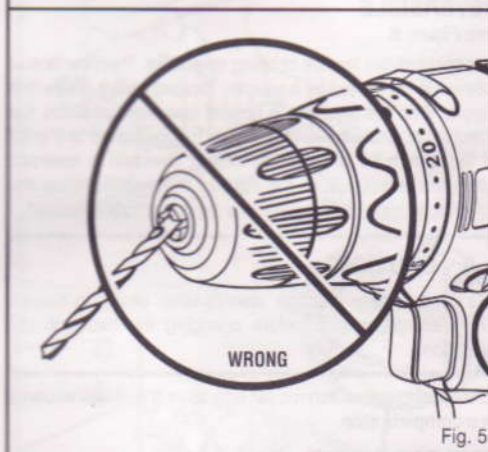

Fig. 5

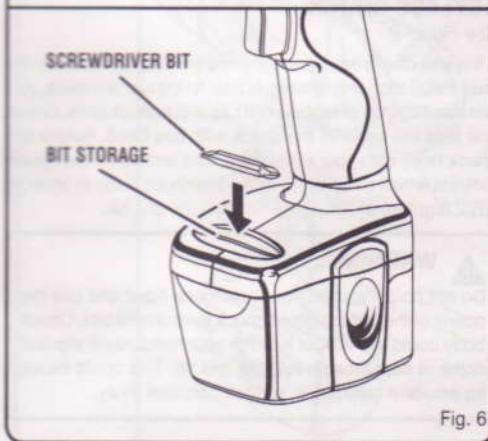

Fig. 6

SWITCH

See Figure 7.

To turn the drill **ON**, depress the switch trigger. To turn it **OFF**, release the switch trigger.

VARIABLE SPEED

See Figure 7.

The drill has a variable speed feature in the switch. The switch delivers higher speed and torque with increased trigger pressure. Speed is controlled by the amount of switch trigger depression.

SWITCH LOCK

See Figure 7.

The switch trigger can be locked in the **OFF** position. This feature helps reduce the possibility of accidental starting when not in use. To lock the switch trigger, place the direction of rotation selector in the center position.

REVERSIBLE

See Figure 8.

This tool has the feature of being reversible. The direction of rotation is controlled by a selector located above the switch trigger. With the drill held in normal operating position, the direction of rotation selector should be positioned to the left of the switch for drilling. The drilling direction is reversed when the selector is to the right of the switch. When the selector is in center position, the switch trigger is locked.

⚠ CAUTION:

To prevent gear damage, always allow chuck to come to a complete stop before changing the direction of rotation.

To stop, release switch trigger and allow the chuck to come to a complete stop.

KEYLESS CHUCK

See Figure 9.

A keyless chuck has been provided with the drill to allow for easy installation and removal of bits. As the name implies, you can hand tighten or release drill bits in the chuck jaws. Grasp and hold the collar of the chuck with one hand. Rotate the chuck body with your other hand. The arrows on the chuck indicate which direction to rotate the chuck body in order to GRIP (tighten) or RELEASE (unlock) the drill bit.

⚠ WARNING:

Do not hold the chuck body with one hand and use the power of the drill to tighten chuck jaws on drill bits. Chuck body could slip in your hand or your hand could slip and come in contact with rotating drill bit. This could cause an accident resulting in serious personal injury.

FORWARD / REVERSE SELECTOR WITH CENTER LOCK POSITION

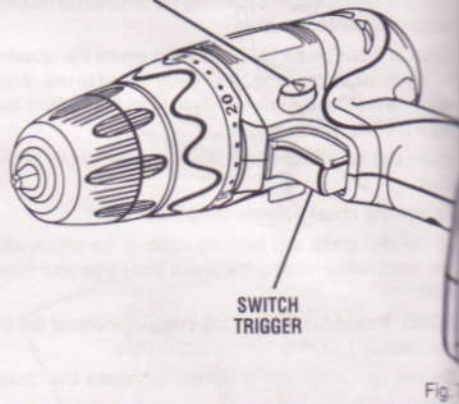

SELECTOR REVERSE

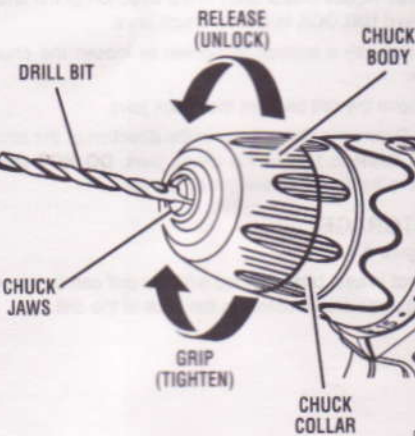
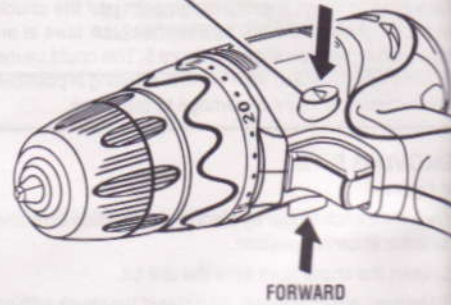

⚠ WARNING:

Battery tools are always in operating condition. Therefore, switch should always be locked when not in use or carrying at your side.

DRILLING

See Figure 10.

When drilling hard, smooth surfaces, use a center punch to mark the desired hole location. This will prevent the drill bit from slipping off center as the hole is started. However, the lower speed feature allows starting holes without center punching if desired. To accomplish this, simply operate the drill at lower speed until the hole is started.

The material to be drilled should be secured in a vise or with clamps to keep it from turning as the drill bit rotates.

Hold tool firmly and place the bit at the point to be drilled. Depress the switch trigger to start tool.

Move the drill bit into the workpiece, applying only enough pressure to keep the bit cutting. Do not force or apply side pressure to elongate a hole.

⚠ WARNING:

Be prepared for binding at bit breakthrough. When these situations occur, the drill has a tendency to grab and kick opposite to the direction of rotation and could cause loss of control when breaking through material. If you are not prepared, this loss of control can result in possible serious injury.

When drilling metals, use a light oil on the drill bit to keep it from overheating. The oil will prolong the life of the bit and increase the drilling action.

If the bit jams in workpiece or if the drill stalls, release switch trigger immediately. Remove the bit from the workpiece and determine the reason for jamming.

LEVEL DRILLING

See Figure 11.

Another convenient feature provided with the drill is a level. It is recessed in the motor housing on top of the drill. It can be used to keep drill bit level during horizontal drilling operations.

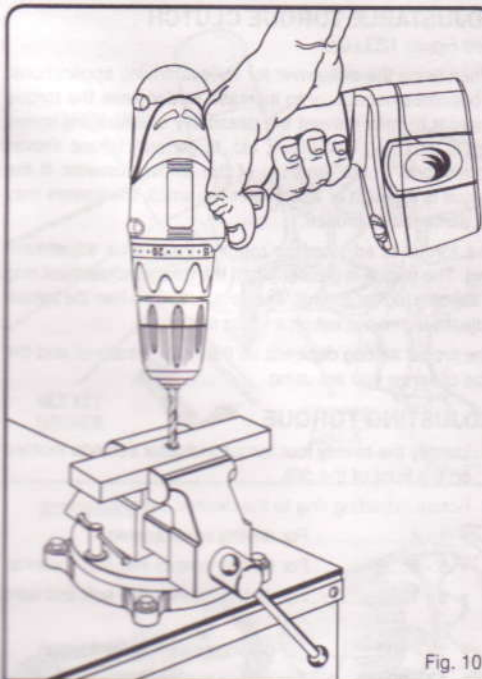

Fig. 10

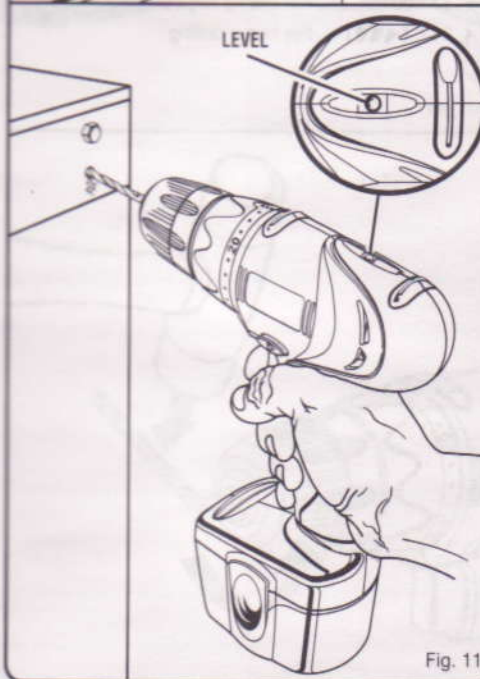

Fig. 11

ADJUSTABLE TORQUE CLUTCH

See Figure 12.

When using the drill-driver for various driving applications, it becomes necessary to increase or decrease the torque in order to help prevent the possibility of damaging screw heads, threads, workpiece, etc. In general, torque should correspond to the intensity of the screw diameter. If the torque is too high or the screws too small, the screws may be damaged or broken.

The torque is adjusted by rotating the torque adjustment ring. The torque is greater when the torque adjustment ring is set on a higher setting. The torque is less when the torque adjustment ring is set on a lower setting.

The proper setting depends on the type of material and the size of screw you are using.

ADJUSTING TORQUE

- Identify the twenty four torque indicator settings located on the front of the drill.
- Rotate adjusting ring to the desired setting.
 - 1 - 4 For driving small screws
 - 5 - 8 For driving screws into soft material
 - 9 - 12 For driving screws into soft and hard materials
 - 13 - 16 For driving screws in hard wood
 - 17 - 20 For driving large screws
 - 21 - (▲▲▲) For heavy drilling

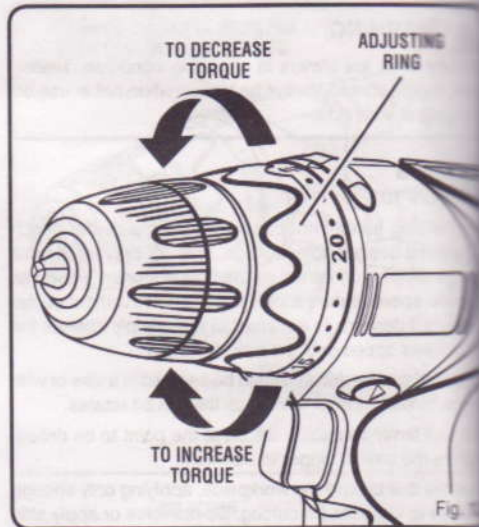

⚠ WARNING:

When servicing, use only identical Ryobi replacement parts. Use of any other parts may create a hazard or cause product damage.

⚠ WARNING:

Always wear safety goggles or safety glasses with side shields during power tool operation or when blowing dust. If operation is dusty, also wear a dust mask.

⚠ WARNING:

To avoid serious personal injury, always remove the battery pack from the tool when cleaning or performing any maintenance.

GENERAL MAINTENANCE

Avoid using solvents when cleaning plastic parts. Most plastics are susceptible to damage from various types of commercial solvents and may be damaged by their use. Use clean cloths to remove dirt, dust, oil, grease, etc.

⚠ WARNING:

Do not at any time let brake fluids, gasoline, petroleum-based products, penetrating oils, etc., come in contact with plastic parts. Chemicals can damage, weaken or destroy plastic which may result in serious personal injury.

Only the parts shown on the parts list are intended to be repaired or replaced by the customer. All other parts should be replaced at a Ryobi Authorized Service Center.

CHUCK REMOVAL

See Figures 13 - 15.

To remove chuck:

- Lock the switch trigger by placing the direction-of-rotation selector in center position.
- Insert a 5/16 in. or larger hex key into the chuck of the drill and tighten the chuck jaws securely.
- Tap the hex key sharply with a mallet in a clockwise direction. This will loosen the screw in the chuck for easy removal.
- Open the chuck jaws and remove the hex key. Remove the chuck screw by turning it in a clockwise direction.

NOTE: The screw has left hand threads.

- Insert the hex key in the chuck and tighten chuck jaws securely. Tap sharply with a mallet in a counterclockwise direction. This will loosen the chuck on the spindle. It can now be unscrewed by hand.

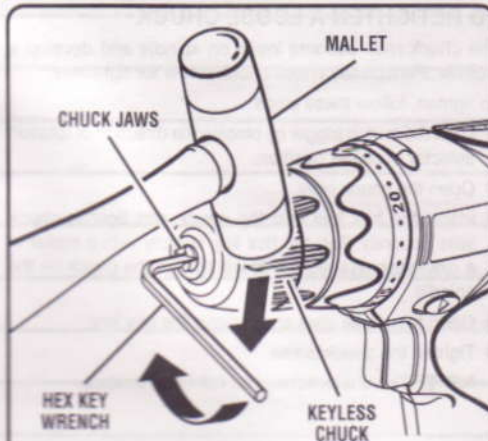

Fig. 13

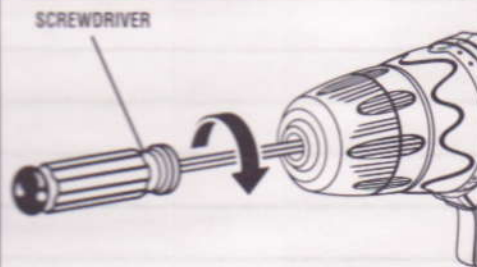

Fig. 14

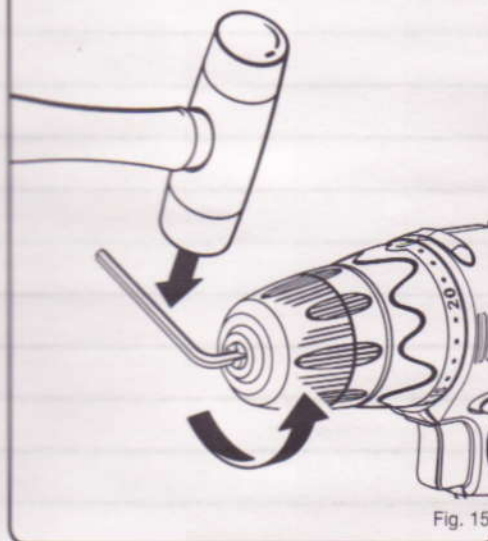

Fig. 15

TO RETIGHTEN A LOOSE CHUCK

The chuck may become loose on spindle and develop a wobble. Periodically check chuck screw for tightness.

To tighten, follow these steps:

- Lock the switch trigger by placing the direction of rotation selector in center position.
- Open the chuck jaws.
- Insert the hex key into the chuck and tighten chuck jaws securely. Tap the hex key sharply with a mallet in a clockwise direction. This will tighten the chuck on the spindle.
- Open the chuck jaws and remove the hex key.
- Tighten the chuck screw.

NOTE: The chuck screw has left hand threads.

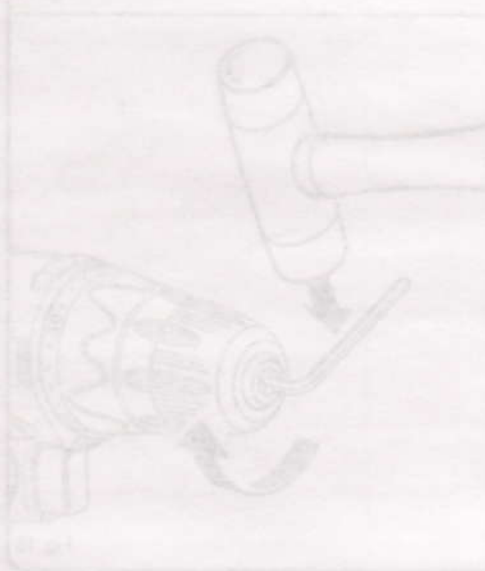
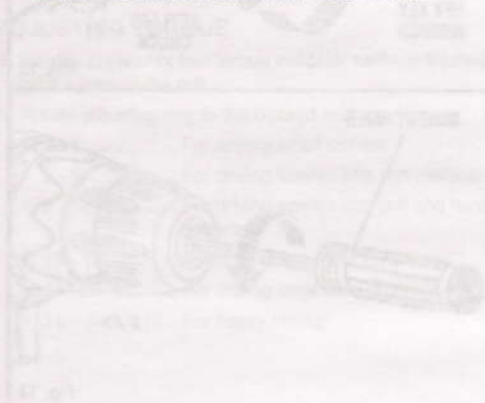

BATTERIES

The battery pack for this tool is equipped with nickel-cadmium rechargeable batteries. Length of service from each charge will depend on the type of work you are doing.

The batteries in this tool have been designed to provide maximum trouble-free life. However, like all batteries, they will eventually wear out. **Do not** disassemble batteries and attempt to replace the batteries. Handling of the batteries, especially when wearing rings and jewelry, can result in a serious burn.

To obtain the longest possible battery life, we suggest the following:

- Remove the battery pack from the charger once it is fully charged and ready for use.

For battery storage longer than 30 days:

- Store the battery pack where the temperature is below 80°F.
- Store battery packs in a "discharged" condition.

BATTERY PACK REMOVAL AND PREPARATION FOR RECYCLING



To preserve natural resources, please recycle or dispose of batteries properly.

This product contains nickel-cadmium batteries. Local, state or federal laws may prohibit disposal of nickel-cadmium batteries in ordinary trash.

Consult your local waste authority for information regarding available recycling and/or disposal options.

WARNING:

Upon removal, cover the battery pack's terminals with heavy-duty adhesive tape. Do not attempt to destroy or disassemble battery pack or remove any of its components. Nickel-cadmium batteries must be recycled or disposed of properly. Always never touch both terminals with metal objects and body parts as short circuit may result. Keep away from children. Failure to comply with these warnings could result in fire and/or serious injury.