

Eppendorf Research® fix · variable · multi

Instruction Manual · Bedienungsanleitung · Mode d'emploi
Istruzioni d'impiego · Manual de Instrucciones

Production

eppendorf

Single-Channel / Einkanal

Research variable

0.1 - 2.5 μL
0.5 - 10 μL
2 - 20 μL

10 - 100 μL

20 - 200 μL

Research fix

- 20 μL

- 100 μL

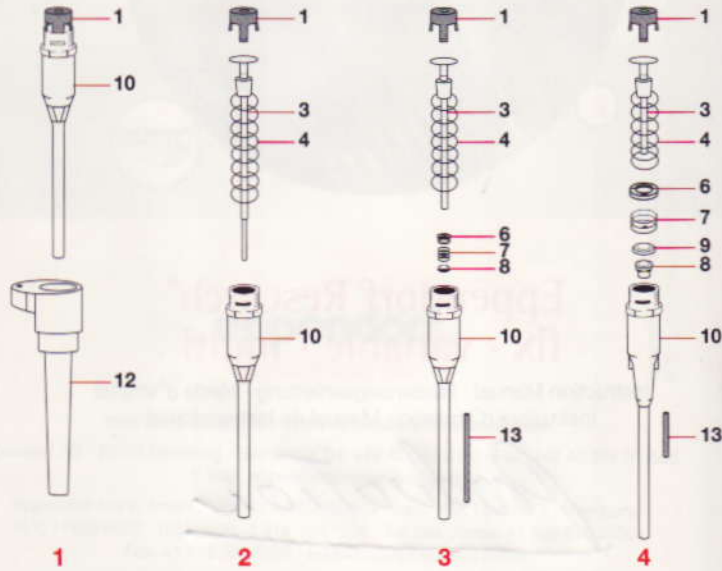

1

2

3

4

100 – 1000 μ L

500 – 5000 μ L

1 – 10 mL

- 1000 μ L

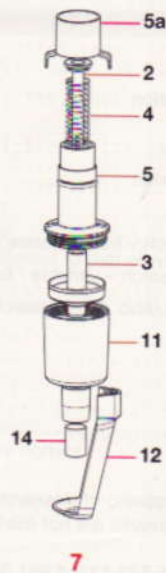
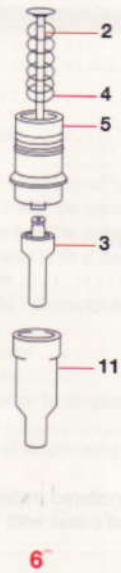

Part A / Teil A / Section A / Parte A / Parte A

Instruction Manual	5
Bedienungsanleitung	20
Mode d'emploi	35
Instruzioni d'impiego	50
Manual de Instrucciones	65

Part B / Teil B / Section B / Parte B / Parte B

Maintenance	80
Ordering Information	89
Wartung	99
Bestellinformationen	108

Fig./Abb. Research – Maintenance / Wartung

Fig./Abb. 1 Research – variable / fix	3
---	---

Fig./Abb. 7 – Fig./Abb. 11 Research – multi-channel / Mehrkanal	119
---	-----

eppendorf and eppendorf Research are registered trademarks.
Registered trademarks are not marked in all cases with TM or [®] in this manual.

U.S. Patent No. 5,531,131; 4,961,350

No part of this publication may be reproduced without the prior permission of the
copyright owner.

Copyright © 2007 Eppendorf AG, Hamburg

1	Safety precautions and applicational limitations	6
1.1	Handling	6
1.2	Care and maintenance	6
2	Technical data	7
2.1	Research, fixed-volume	7
2.2	Research, adjustable-volume (variable)	7
2.3	Research, multi-channel, adjustable-volume (variable) (8- and 12-channel)	8
3	Function principle	8
4	Operation	10
4.1	Volume setting (not valid for fixed-volume model)	10
4.2	Pipette tips	10
4.3	Aspirating liquid	10
4.4	Dispensing liquid	11
4.5	Special notes	11
5	Testing / alignment	12
5.1	Testing	12
5.2	Alignment	12
5.2.1	When should alignment be carried out?	12
5.2.2	Follow-up alignment in the case of error	13
5.2.3	Adjustment for liquids with a density different to that of water	15
6	Care / sterilization	15
6.1	Care	15
6.2	Sterilization	16
6.2.1	Single-channel model	16
6.2.2	Multi-channel model	17
6.3	Decontamination prior to dispatch	17
7	Troubleshooting	18
	If there is doubt that dispensing data are correct	19

1 Safety precautions and applicational limitations

The Research pipette is a lab device. It may only be operated by appropriately qualified lab personnel.

Before working with the Research pipette, please read the operating manual. To ensure safe, problem-free experiments with the Research pipette, it is essential to observe the following points:

1.1 Handling

- Only use pipettes in the Research Family when a pipette tip has been attached.
- Pipette tips are solely designed for disposable usage.
- Use the 1 – 10 mL pipette only with filter inserted.
- Do not lay down the pipette when a filled pipette tip is attached.
- When using infectious, radioactive, toxic and/or solutions that pose a health risk, please observe the safety precautions valid for the country in which the pipette is being used.
- When using organic solvents and aggressive chemicals, check the suitability of use with pipette tips (made of PP = polypropylene) and the pipettes.
- When using solutions with physical characteristics which are considerably different to those of water (e.g. glycerol), check the dispensing volume as described in Section 5.2.
- Avoid differences in temperature between pipettes and pipette tips as well as the liquid used as this may lead to incorrect volumes being dispensed.
- The above may also occur when liquids with a high vapor pressure are used.

1.2 Care and maintenance

- Do not allow any liquid to enter into the pipette.
- Do **not** clean the pipette with acetone or aggressive solutions.
- Use original spare parts and accessories (pipette tips) only.

2 Technical data

2.1 Research, fixed-volume

Model/volume μL	Color code	epT.I.P.S. μL	Systematic error		Random error	
			%	μL	%	μL
10	yellow	2- 200	± 1.2	± 0.12	± 0.6	± 0.06
20	yellow	2- 200	± 1.0	± 0.2	± 0.3	± 0.06
25	yellow	2- 200	± 1.0	± 0.25	± 0.3	± 0.075
50	yellow	2- 200	± 0.7	± 0.35	± 0.3	± 0.15
100	yellow	2- 200	± 0.6	± 0.6	± 0.2	± 0.2
200	blue	50-1,000	± 0.6	± 1.2	± 0.2	± 0.4
250	blue	50-1,000	± 0.6	± 1.5	± 0.2	± 0.5
500	blue	50-1,000	± 0.6	± 3	± 0.2	± 1
1,000	blue	50-1,000	± 0.6	± 6	± 0.2	± 2

2.2 Research, adjustable-volume (variable)

Model μL	Color code	epT.I.P.S. μL	Volume μL	Systematic error		Random error	
				%	μL	%	μL
0.1- 2.5	dark gray	0.1- 10	0.25	± 12.0	± 0.03	± 6.0	± 0.015
			1.25	± 2.5	± 0.031	± 1.5	± 0.019
			2.5	± 1.4	± 0.035	± 0.7	± 0.018
0.5- 10	light gray	0.5- 20	1	± 2.5	± 0.025	± 1.8	± 0.018
			5	± 1.5	± 0.075	± 0.8	± 0.04
			10	± 1.0	± 0.1	± 0.4	± 0.04
2- 20	yellow	2- 200	2	± 5.0	± 0.1	± 1.5	± 0.03
			10	± 1.2	± 0.12	± 0.6	± 0.06
			20	± 1.0	± 0.2	± 0.3	± 0.06
10- 100	yellow	2- 200	10	± 3.0	± 0.3	± 1.0	± 0.1
			50	± 1.0	± 0.5	± 0.3	± 0.15
			100	± 0.8	± 0.8	± 0.2	± 0.2
20- 200	yellow	2- 200	20	± 2.5	± 0.5	± 0.7	± 0.14
			100	± 1.0	± 1	± 0.3	± 0.3
			200	± 0.6	± 1.2	± 0.2	± 0.4
100-1,000	blue	50-1,000	100	± 3.0	± 3	± 0.6	± 0.6
			500	± 1.0	± 5	± 0.2	± 1
			1,000	± 0.6	± 6	± 0.2	± 2
500-5,000	violet	100-5,000	500	± 2.4	± 12	± 0.6	± 3
			2,500	± 1.2	± 30	± 0.25	± 6.25
			5,000	± 0.6	± 30	± 0.15	± 7.5
mL		mL	mL	%	mL	%	mL
1-10	turquoise	1-10 Standard	1	± 3.0	± 0.03	± 0.6	± 0.006
			5	± 0.8	± 0.04	± 0.2	± 0.01
			10	± 0.6	± 0.06	± 0.15	± 0.015

2.3 Research, multi-channel, adjustable-volume (variable) (8- and 12-channel)

Model μL	Color code	epT.I.P.S. μL	Volume μL	Systematic error		Random error	
				%	μL	%	μL
0.5– 10	light gray	0.5– 20	1	± 8.0	± 0.08	± 5.0	± 0.05
			5	± 4.0	± 0.2	± 2.0	± 0.1
			10	± 2.0	± 0.2	± 1.0	± 0.1
10–100	yellow	2–200	10	± 3.0	± 0.3	± 2.0	± 0.2
			50	± 1.0	± 0.5	± 0.8	± 0.4
			100	± 0.8	± 0.8	± 0.3	± 0.3
30–300	orange	20–300	30	± 3.0	± 0.9	± 1.0	± 0.3
			150	± 1.0	± 1.5	± 0.5	± 0.75
			300	± 0.6	± 1.8	± 0.3	± 0.9

The technical data is valid only when the quoted Eppendorf pipette tips are used.

Tests carried out in accordance with ISO 8655 for piston-stroke pipettes with an air cushion using a fine balance with moisture trap approved by the standardization authorities.

Note: on the 1–10 mL pipette, when the 1–10 mL tip, long (see ordering information) is used, the quoted tolerance range increases by a factor of 2 compared to when the standard tip is used.

Number of determinations:

10; degassed, bidistilled water,

20 °C – 25 °C, constant to ± 0.5 °C; with pre-wetted pipette tip;

dispensing carried out on inner wall of vessel.

If the place where the pipette is used is at extremely high altitude, an adjustment must be made in line with the ambient air pressure.

3 Function principle

The pipettes belonging to the Research Family are piston-stroke pipettes that operate according to the air-cushion principle.

The Research Family consists of fixed-volume pipettes, adjustable-volume (variable) pipettes and eight- and twelve-channel pipettes, which also have an adjustable-volume (variable) setting.

All models belonging to the Research Family have separate tip ejection.

Each channel of the multi-channel model has its own piston, which means that is possible to attach fewer than eight or twelve tips.

In addition, the lower part can be rotated into a user-defined position as required.

It is possible to choose between a lower part for eight channels and for twelve channels. Both cover the same volume range.

Fig. 2 Research (single-channel) and multi-channel lower part

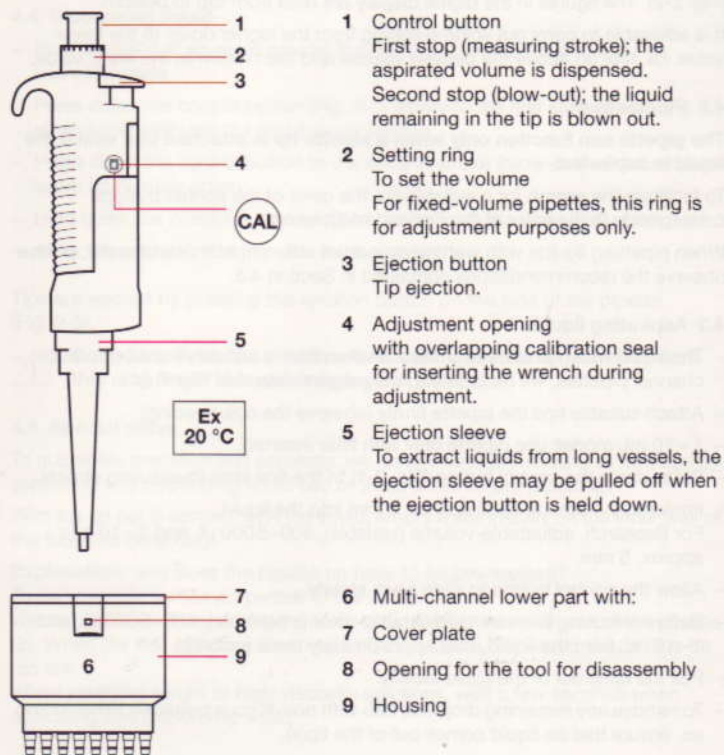

- 1 Control button
First stop (measuring stroke); the aspirated volume is dispensed.
Second stop (blow-out); the liquid remaining in the tip is blown out.
- 2 Setting ring
To set the volume
For fixed-volume pipettes, this ring is for adjustment purposes only.
- 3 Ejection button
Tip ejection.
- 4 Adjustment opening
with overlapping calibration seal
for inserting the wrench during adjustment.
- 5 Ejection sleeve
To extract liquids from long vessels, the ejection sleeve may be pulled off when the ejection button is held down.

- 6 Multi-channel lower part with:
- 7 Cover plate
- 8 Opening for the tool for disassembly
- 9 Housing

4 Operation

4.1 Volume setting (not valid for fixed-volume model)

The volume can be changed continuously by rotating the setting ring (Fig. 2-2). The figures in the digital display are read from top to bottom.

It is advisable to carry out volume setting from the higher down to the lower value. i.e. first go above the desired volume and then return to the lower value.

4.2 Pipette tips

The pipette can function only when a pipette tip is attached into which the liquid is aspirated.

To facilitate the search for a suitable tip, the color of the control buttons corresponds to the color of the Eppendorf tip racks.

When pipetting liquids with wetting properties different to those of water, please observe the recommendations contained in Section 4.5.

4.3 Aspirating liquid

- The liquid which is to be aspirated is taken from a suitable vessel (for multi-channel pipettes, we recommend the reagent reservoir "Tip-Tub").
- Attach suitable tips the pipette firmly (observe the color coding).
- 1 – 10 mL model: use pipette only with filter inserted.
- Press down the control button (Fig. 2-1) to the first stop (measuring stroke).
- Immerse the pipette tip(s) approx. 3 mm into the liquid.
For Research, adjustable-volume (variable), 500–5000 μL and 1 – 10 mL:
approx. 5 mm.
- Allow the control button to slide back **slowly**.
- Before removing Research, adjustable-volume (variable), 500–5000 μL and 1 – 10 mL from the liquid, wait approximately three seconds.
- Pull the tip(s) out of the liquid **slowly**.
- To remove any remaining droplets, dab with non-fibrous cellulose. When doing so, ensure that no liquid comes out of the tip(s).

Note:

For Research, adjustable-volume (variable), 500–5 000 μL and 1–10 mL: if the tip is removed from the liquid too quickly, coaxial forces may push liquid out of the tip. This may result in the pipetted volume being too low.

4.4 Dispensing liquid

- Hold the tip(s) at an angle against the inside wall of the tube/well of the microtiter plate.
- Press down the control button (Fig. 2-1) slowly to the first stop (measuring stroke) and wait until the liquid stops flowing.
- Press down the control button to the second stroke (blow-out) until the tip(s) is/are completely empty.
- Hold down the control button and pull the tip(s) up the inner wall of the tube.
- Allow the control button to slide back slowly.

Tips are ejected by pressing the ejection button on the side of the pipette (Fig. 2-3).



Do not lay down the pipette when a filled pipette tip is attached as this may result in liquid entering the pipette!

4.5 Special notes

To guarantee precision and accuracy, we recommend pre-wetting all new tips by aspirating and dispensing liquid two or three times before pipetting.

With the tip not in contact with the liquid, empty it completely on the inner wall of the tube (via blow-out).

Explanation: why does the pipette tip have to be **pre-wetted**?

To compensate for the properties of the liquid.

Wetting liquids (serum, detergent) form a thin film on the inner wall of the pipette tip. When the first pipetting is carried out, the volume dispensed would thus be too low.

When pipetting serum or high-viscosity solutions, wait a few seconds when aspirating and dispensing liquid.

5 Testing / alignment

The serial number is on the setting ring on the control button.

5.1 Testing

Research, single-channel

Distilled water is dispensed from a pre-wetted tip into a tube and is then weighed.

Volumes 0.1 – 10 μL :

The test is performed with a highly sensitive analytic balance (resolution balance 0.001 mg) by releasing the volume.



The bidistilled water, weighing vessel, pipette and pipette tip must all be the same temperature!

To calculate the volume, divide the weight by the density of the water (at 20 °C: 0.9982 mg/ μL ; mg/ μL = g/mL).

Volumes > 10 μL – 10 mL:

For a volume of more than 10 μL , a balance with a resolution of 0.01 mg is sufficient.

Research, multi-channel

Multi-channel pipettes are usually tested by dispensing the volume from a pre-wetted tip into a tube.

5.2 Alignment

5.2.1 When should alignment be carried out?

The pipettes belonging to the Research Family were tested with water during production in accordance with ISO 8655 and provided with a calibration seal at the factory.

In the case of doubts arising with regard to the accuracy of the pipetted volume the following points should be clarified:

- Is the pipette leaking? (This is one possible reason for dispensed volumes being too low; troubleshooting and solutions are contained in Sec. 7.)

- What is the temperature of the sample? (In open tubes, water at room temperature evaporates)
- What is the temperature of the pipette?
- What is the temperature of the air?
- Has mg been converted into μL ?
- Does the sample have a different density to that of water?
- Is the pipetting speed too high?

If the place where the pipette is used is at extremely high altitude, an adjustment must be made in line with the ambient air pressure. At 1,000 m above sea level, there is a volume error of approx. -0.4 %.

Assistance with these questions is contained in Eppendorf's SOP (Standard Operating Procedure), which is available upon request. An SOP can be called up from our home page www.eppendorf.com.

If these checks prove to be unsuccessful, it is safe to assume that the alignment of the pipette has altered (e.g. due to several components having been replaced).

5.2.2 Follow-up alignment in the case of error

From a technical point of view, this is a zero-point shift. The value by which the setting of the pipette is shifted remains constant across the entire measuring range. If, for example, in the case of a 10–100 μL , follow-up alignment of 1 μL takes place at 100 μL (=1 %), the pipette is also adjusted by 1 μL at 10 μL (=10 %!)

- a The pipette, tip and water must all be the same temperature (20–25 °C, constant to ± 0.5 °C).
- b In the case of adjustable pipettes, the pipette is set to the nominal volume required.
- c With a pipette tip attached to the pipette, the desired volume is pipetted and weighed 10 times (for multi-channel pipettes, this is carried out for each channel). The mean of this weighing is converted into μL using the following formula:

$$\text{Volume} = \frac{\text{Weight}}{\text{Density of liquid (at the temperature specified)}}$$

The value obtained is the actual setting (density of water at 20 °C: 0.9982 mg/ μL).

d To align to the volume displayed, side D (or side B with multi-channel pipettes) of the wrench is inserted horizontally through the calibration seal into the alignment opening (Fig. 2-4) in the pipette grip. (When doing so, hold the pipette vertically.) The wrench is then rotated into a vertical position. The calibration seal is thereby destroyed and removed.

e Research, adjustable-volume (variable) and multi-channel

When the setting ring is rotated (either in the + or - direction), the piston stroke of the pipette is altered (although the volume-setting dial remains unchanged).

One rotation is equal to the following:

Research, adjustable-volume (variable)		Research, multi-channel	
0.1 – 2.5 μL approx.	0.1 μL	0.5 – 10 μL approx.	0.5 μL
0.5 – 10 μL approx.	0.5 μL	10 – 100 μL approx.	5 μL
2 – 20 μL approx.	1 μL	30 – 300 μL approx.	10 μL
10 – 100 μL approx.	5 μL		
20 – 200 μL approx.	10 μL		
100 – 1000 μL approx.	50 μL		
500 – 5000 μL approx.	250 μL		
1 – 10 mL approx.	510 μL		

Research, fixed-volume

To reduce the volume, turn the setting ring (Fig. 2-2) clockwise. To increase the volume, turn the setting ring counterclockwise.

One rotation is equal to the following:

Research fix

10 μL approx.	0.8 μL	200 μL approx.	38 μL
20 μL approx.	0.8 μL	250 μL approx.	38 μL
25 μL approx.	4 μL	500 μL approx.	38 μL
50 μL approx.	4 μL	1000 μL approx.	38 μL
100 μL approx.	4 μL		

- f Remove the wrench and move the setting ring backwards and forwards until the counter and the stroke system lock together.
- g Repeat step c). The readings must be within the tolerances specified in the technical data.

Is the nominal volume does not correspond with the measuring result, repeat steps d) and e).

Since this adjustment affects the entire measuring range, it is imperative to check the other volumes of this pipette specified in the technical data.
Next, close the adjustment opening with one of the supplied calibration seals.

5.2.3 Adjustment for liquids with a density different to that of water

It is possible to adjust one **specific volume** of liquid with a density different to that of water in such a way that the volume displayed corresponds to the volume pipetted.

All other values for the adjustable pipettes are now out of alignment, i.e. an adjustable-volume (variable) pipette has been converted into a fixed-volume pipette!

Proceed as described in steps a) to g) of Section 5.2.2.



A pipette set in this way delivers a pipetting value that correlates with that in the display **only for the liquid used and for the volume tested!** For this reason, we recommend labeling the converted pipette as a **fixed-volume pipette** for "Solution y"!

The error for liquids with a higher vapor pressure (e.g. organic solvents) cannot be aligned in this way. In this case, we recommend using an Eppendorf positive-displacement pipette.

6 Care / sterilization

6.1 Care

Depending on the frequency of use, all pipettes should be cleaned in a soap solution or should be carefully wiped clean using isopropanol. They should then be rinsed in distilled water and dried.

The seals are maintenance-free and the pistons should be lubricated lightly (using the silicone grease provided) when cleaned or replaced.

With the multi-channel model, the visible O-rings on the tip holder should be lightly lubricated after cleaning and then wiped using a lint-free cloth. Defective O-rings must be replaced (see Part B, "Maintenance").

Severe contamination caused by the liquid entering the pipette can be removed after the pipette has been disassembled (see Part B, "Maintenance").

In order to ensure the consistent quality of the pipettes, we recommend using the corresponding parts of the same generation (PhysioCare Concept + PhysioCare Concept, Standard + Standard*).

* please review old operating instructions

Visual differentiating features of PhysioCare Concept pipettes:



Single-channel

Multi-channel



Black piston holder



Black tip holder

6.2 Sterilization

The lower half of the pipette can be sterilized by means of steam-autoclaving (121 °C, 1 bar, 20 minutes).

If necessary, allow the autoclaved parts to dry at room temperature. Do not reassemble the pipette until it has cooled down completely.

6.2.1 Single-channel model

With single-channel models, the ejection sleeve (Fig. 1-12) and the lower part (Fig. 1-10) may be autoclaved.

To do so, hold down the ejection button and pull off the ejection sleeve, then unscrew the pipette lower part (with pipettes up to 1000 µL, this may require the assistance of opening A of the wrench provided, see Fig. 3).

Single-channel, adjustable-volume (variable) 500 - 5000 µL

The piston must be removed before the pipette lower part can be unscrewed (see Part B, "Maintenance").

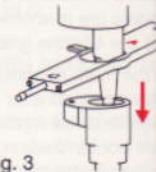

Fig. 3

Variant 1 – 10 mL (Fig. 1-14)

Pull filter down out of the nose cone. The filter swells up slightly during autoclaving. Compress gently when reinserting. This does not impair function. Only autoclave filter 1x. Unscrew the complete lower part from the grip by turning to the left, **not** turning the ejection sleeve (Fig. 1-12) at the same time. The ejection sleeve comes out of its bracket automatically during turning and can be removed from the lower part.

6.2.2 Multi-channel model

With the multi-channel model, the complete lower part (Fig. 2-6) is placed into the autoclave.

To do so, hold down the ejection button and unscrew the lower part from the grip by rotating it counterclockwise.

All pipettes belonging to the Research Family may be exposed to UV light. Any discoloration which may occur has no effect on the function of the pipette.

6.3 Decontamination prior to dispatch

 **If the Research pipette is to be checked, repaired or calibrated by Eppendorf AG or another service partner, it must be free of hazardous substances and clean!**

A form called "Decontamination certificate for return of goods" and general notes about decontamination are available on our home page:

www.eppendorf.com

A signed decontamination certificate must be enclosed with the pipette when it is returned. The serial number of the Research must be entered on the decontamination certificate.

The bottom part of the Research can be decontaminated of potentially infectious substances by being steam-autoclaved (see Sec. 6.2).

The surfaces of the pipette can be disinfected with alcohol (ethanol, propanol) or with a disinfectant containing alcohol.

7 Troubleshooting

Error	Cause	Solution
Droplets on the inner wall of the pipette tip.	<ul style="list-style-type: none"> - Uneven wetting of the plastic wall. - A pipette tip with poor wetting properties has been used. 	<ul style="list-style-type: none"> - Attach a new pipette tip. - Use an original Eppendorf tip.
Pipette is dripping and/or the volume pipetted is incorrect.	<ul style="list-style-type: none"> - The tip is loose. - A poorly fitting pipette tip has been used. - Liquid with a high vapor pressure has been pipetted. <p>For 500–5000 μL/1–10 mL pipette:</p> <ul style="list-style-type: none"> - Pipetting was too fast. - The tip was removed too quickly from the liquid. - The pipette is dripping because: <ul style="list-style-type: none"> piston is contaminated. - Piston is damaged. - Seal is damaged. <p>The pipette lower part is loose.</p> <p>For multi-channel model:</p> <ul style="list-style-type: none"> - The O-ring of the channel is damaged. 	<ul style="list-style-type: none"> - Press the tip on firmly. - Use an original Eppendorf tip. - In this case, we recommend pipetting using a positive displacement pipette. - Allow the control button to slide back slowly. - Pull the tip slowly out of the liquid. - Clean and lightly lubricate the piston (Part B, "Maintenance"). - Replace the piston and seal (Part B, "Maintenance"). - Replace the seal; with the 500–5000 μL and 1–10 mL model, replace the piston (Part B, "Maintenance"). - Tighten the pipette lower part by hand. - Replace defective O-ring (Part B, "Maintenance").

Error	Cause	Solution
The control button jams and does not move smoothly.	- The piston is contaminated.	- Clean the piston and lubricate lightly (Part B, "Maintenance").
	- The seal is contaminated.	- Remove the piston from the pipette lower part (Part B, "Maintenance"). Rinse out the lower part with warm water, then rinse with distilled water and allow to dry. Replace the seal if necessary.
	- Solvent vapors have entered the pipette.	- Remove the piston from the lower part (Part B, "Maintenance") and aerate the lower part. Clean and lightly lubricate the piston.
Pipette blocked; too little liquid is aspirated.	- Liquid has entered the nose cone and dried.	- Remove the piston from the pipette lower part (Part B, "Maintenance"). Rinse out the lower part with warm water, then rinse with distilled water and allow to dry.

If there is doubt that dispensing data are correct

To avoid dispensing errors, the precision and accuracy of the Research need to be checked regularly. The PICASO II software program (see ordering information) is available to determine permitted systematic and random measuring deviation (see Section 2 "Technical data"). An SOP (Standard Operating Procedure) for checking pipettes can be called up from our home page www.ependorf.com.

For liquids whose physical data deviate significantly from those of water, calibration needs to be changed in accordance with Section 5.2.3. Calibration will also need to be changed if the pipette is being used at a very high altitude.

Maintenance

I. Single-channel model	82
A Disassembly and assembly	82
B Replacing pistons and seals	82
II. Multi-channel model	86
A Replacing the O-rings	86
B Replacing the piston seals	86

Ordering information

I. Fixed-volume pipettes	89
II. Adjustable-volume pipettes	90
III. Multi-channel pipettes	92
IIIa. Additional accessories	93
IV. Pipette holder	93
V. Pipette tips	93

Fig./Abb. Research – Maintenance / Wartung 119



Please use only the accessories recommended by Eppendorf. Using spare parts and consumables that we have not recommended may reduce the precision, accuracy and life of the devices. We do not honor any warranty or accept any responsibility for damage resulting from such action.

Guarantee and warranty

In the case of warranty claims please contact your responsible Eppendorf contractual partner.

Wear-and-tear parts are excluded from the warranty. When returning the pipette to the Eppendorf contractual partner the necessary data for utilization and the performance of decontamination (see section 6.3) should be included.

Service must be carried out by the Service of the Eppendorf contractual partner.

No warranty shall apply with misuse or opening of the device by unauthorized persons.

For information on replacing pistons and seals as well as on disassembling and assembling the different members of the Research family, please see page 3 and page 115 of this manual.

Single-channel pipettes

All maintenance work is carried out using this wrench.

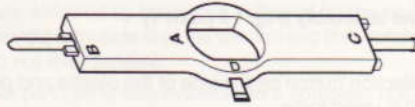

Fig. 4

Opening A: to loosen the pipette lower part from the grip.

Side B: to replace the seals.

Side C: to replace the seals.

Side D: to align the pipette.

Multi-channel pipettes

All maintenance work is carried out using this tool.

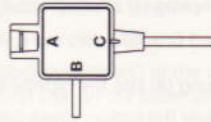

Fig. 5

Side A: to replace the O-rings on the nose cones.

Side B: to remove the lower housing, to loosen the metal clips, to remove the press piece and to align the pipette.

Side C: to replace the seals.

1. Single-channel model

Please see page 3 (Fig. 1) of this manual.
 A general description of disassembly and assembly for all single-channel models is followed by instructions on how to replace specific parts for special pipette types.

A Disassembly and assembly (Fig. 1 / point 1)

Disassembly

- Hold down the ejection button on the side of the pipette and pull off the

ejection sleeve (12) using force.

An exception is the 1 - 10 mL model:

see Section B "Replacing pistons and seals".

- Unscrew the pipette lower part (10) from the grip by turning it to the left

(if necessary, use position A of the wrench provided).

- Press the piston holder (1) together and remove it.



The piston is subject to spring tension!

- Remove the piston (3) with spring (4) and replace if necessary.

Assembly

- Insert the piston (3) with spring (4) into the pipette lower part.

- Place the piston holder (1) over the piston, press it together and slide it into the

grooves on the lower part.

- Screw the pipette lower part hand-tight into the grip. (Do not use the wrench)

- Hold down the ejection button and re-attach the ejection sleeve.

B Replacing pistons and seals

For fixed- and adjustable-volume (variable) pipettes up to 20 µL (see Fig. 1 /

point 2):

- Disassemble the pipette.

- The seal is changed by replacing the entire pipette lower part (10).

For fixed- and adjustable-volume (variable) pipettes up to **100 μL** (see Fig. 1 / point 3):

- Disassemble the pipette.
- Using side B of the wrench, undo the screw (6) and tap out the internal spring (7).
- Press in side C of the wrench, pull out the seal and O-ring (8) and replace.
- Push the screw, followed by the spring, followed by the seal (with the O-ring facing downwards) onto side B of the wrench and then rotate it into the pipette lower part (do not over-tighten).

The pipette lower part (10) is also available as a complete unit, with seal.

Replacing the filling tube (13)

- Disassemble the pipette lower part.
- After removing the seal, push out the filling tube from below using the wire punch and push in a new tube from above. Replace the seal at the same time.

Research, adjustable-volume, **20 – 200 μL** (see Fig. 1 / point 4):

- Disassemble the pipette.
- Undo the screw (6) using side C of the wrench.
- Tap out the spring (7), the press piece (9) and the seal (8). Replace the seal.
- Slide the centering aid (tube) over side C of the wrench. Push the screw, spring, press piece and new seal (in the order shown) on to the wrench and screw it into the lower part.

The pipette lower part (10) is also available as a complete unit, with seal.

Replacing the filling tube (13)

- Disassemble the pipette lower part.
- After removing the seal, push out the filling tube from below using the wire punch and push in a new tube from above.

Fixed- and adjustable-volume (variable) pipettes **up to 1000 μL**
(see Fig. 1 / point 5):

- Disassemble the pipette.
- Undo the screw (6) using side C of the wrench.
- Tap out the spring (7), the press piece (9) and the seal (8). Replace the seal.
- Attach the spring to the new seal and then insert both parts, together with the screw, into the pipette lower part and tighten.
The pipette lower part (10) is also available as a complete unit, with seal.

Research, adjustable-volume (variable), **500 – 5000 μL** (see Fig. 1 / point 6):

- The seal is changed by replacing the piston (6).
- Hold down the ejection button and pull off the ejection sleeve (12) using force.
- Unscrew the cylinder (11) by turning it to the left.
- Press and hold down the operating button and pull off the piston (3) using force.
- Slide the new piston onto the piston rod up to the stop.
- Screw the cylinder onto the cylinder attachment (5).

For autoclaving:

- Remove the piston (3), as described above.
- Slide the disassembly aid over the cylinder attachment (5) and unscrew it from the pipette upper part by turning it to the left.
- After autoclaving, screw the cylinder attachment with the piston rod (2) and stroke spring (4) into the pipette upper part.
- Slide the piston (3) onto the piston rod up to the stop.
- Screw the cylinder onto the cylinder attachment.

Research variable **1 – 10 mL** (see Fig. 1 / point 7):

the seal is changed by replacing piston (3).

- Pull filter (14) down out of the nose cone.
- Unscrew the complete lower part (10) from the grip by turning to the left, **not** turning the ejection sleeve (12) at the same time. The ejection sleeve comes out of its bracket automatically during turning and can be removed from the lower part.

- Pull the locking mechanism (5a), which is located on the cylinder attachment (5), off upwards.
- Unscrew cylinder (11) from the cylinder attachment (5) by turning to the left.
- Put the disassembly aid supplied over the cylinder attachment (5) from above and press down, which pushes the piston down at the same time.
- Keep the disassembly aid depressed on the cylinder attachment in the lowest position using your forefinger and thumb and use the other hand to pull off the piston (3) using force.
- Keep the disassembly aid depressed and push a new piston onto piston rod (2) up to the stop. Remove the disassembly aid.
- Screw cylinder (11) back up tightly so that the grooves of the cylinder and the cylinder attachment line up.
- Place locking device (5a) on cylinder attachment (5) from above so that the lugs extend into the grooves.
- Put ejection sleeve (12) on the lower part and hold steady.
- Push lower part of pipette (10) into grip with one hand, using the other to fix the ejection sleeve in position in its bracket.
- Screw up the lower part of the pipette firmly.
- Insert a new filter if necessary.

II. Multi-channel model

A Replacing the O-rings

- Hold down the ejection button on the side of the pipette and unscrew the lower part counterclockwise from the grip.
- Push opening A of the tool (suitable for the pipette size at hand) from below over the nose cones in such a way as to ensure that the sharp edge in the opening of the tool is overlapping with the O-ring (see Fig. 6).
- Using your index finger, press the tool from behind against the nose cone. Using your thumb, apply pressure from the other side.
- The O-ring is severed at one point and can be removed from the nose cone.

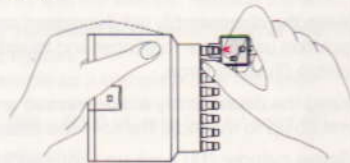

Fig. 6

Attaching a new O-ring

- Attach the assembly aid (shortened pipette tip) onto the nose cone.
- Slide the new O-ring over the tip and onto the nose cone.

B Replacing the piston seals

- Hold down the ejection key and unscrew the lower part (Fig. 2-6) counterclockwise from the grip.
- With the cone facing downwards, place the pipette lower part horizontally onto a table and press it down slightly.
- Press side B of the tool into the opening (Fig. 2-8) in the housing (Fig. 2-9).

! The two stop hooks on the inside are depressed and the cover plate (Fig. 2-7) pops up!

- Please see page 115 of this manual.
- Pull the housing off the cover plate.
- Hold the lower part firmly, as shown in Fig. 7.
- Press side B of the tool under the metal clip and slide it upwards. Lever the clip off the safety hook.
- Turn the lower part until the second clip is facing forwards. When doing so, grip the tip holder with your thumb (the tip holder is subject to spring tension). Lever off the second clip from the safety hook.
- Pull off the tip holder (Fig. 8).
- To **clean the piston**, pull off the springs (the pistons were deliberately loaded unevenly), wipe all pistons (with 60 % isopropanol as required) and lubricate lightly.
- Re-attach the springs and turn them slightly.
- Arrangement of the pistons:

8-channel 0.5 – 10 µL	Pistons 4 and 5
8-channel 10 – 100 µL / 30 – 300 µL	Pistons 3, 4 and 5
12-channel 0.5 – 10 µL	Pistons 6 and 7
12-channel 10 – 100 µL / 30 – 300 µL	Pistons 4, 5, 6 and 7

Removing the seals

- The tip holder contains the following for each channel: press piece, spring and spring plate, with the piston seal underneath (Fig. 9).
- To remove the seals, put your index finger onto the opening of the channel in the tip holder which contains the defective seal.



The press piece is under spring tension and may pop out during removal!

0.5 – 10 µL and 10 – 100 µL

- Press the wire punch (side B) on the tool into the openings on the tip holder and slide the press piece upwards slightly. This loosens the press piece and it can be removed (Fig. 10).

30 – 300 μ L

- Proceed as with the other sizes, The press piece is discarded.
- Using side C of the tool, pull out the spring, spring plate and seal (Fig. 11a) and replace the defective seal.

Assembly

0.5 – 10 μ L and 10 – 100 μ L

- Load side C of the tool with the press piece, then the spring, then the spring plate and then the seal. Re-insert side C into the tip holder and press it in (Fig. 11b). Make sure that the press piece is in the correct position.

30 – 300 μ L

- Place a **new** press piece onto the tool and proceed as with the other sizes.

For all sizes

- The press piece locks into place in the opening of the tip holder.
- Slide the tip holder completely over the piston. When doing so, hold it as shown in Fig. 7.
- Using your thumb, press the first clip firmly upwards over the safety hook. Then rotate the lower part, pressing the tip holder against the upper part when doing so. Using your thumb, press the second clip firmly over the hook.
- Slide on the housing, press the stop hooks together slightly and press down the cover plate until it locks into place.



After the spare parts have been inserted or any other interventions have been made, the pipette must be tested to see whether it is functioning correctly (calibration included).

If these instructions for eliminating faults prove to be unsuccessful, send the pipette to your authorized dealer for repair.

Please see page 3 (Fig. 1) of this manual.
 In order to ensure the consistent quality of the pipettes, we recommend using the
 corresponding parts of the same generation
 (PhysioCare Concept + PhysioCare Concept, Standard + Standard*).
 Please review old operating instructions

Fixed-volume pipettes

Pipettes / spare parts	Order number International	Order number North America
Models:		
10 µL Yellow control button	3112 000.010	022443054
20 µL Yellow control button	3112 000.029	022443101
25 µL Yellow control button	3112 000.037	022443151
50 µL Yellow control button	3112 000.045	022443208
100 µL Yellow control button	3112 000.053	022443259
200 µL Blue control button	3112 000.061	022443305
250 µL Blue control button	3112 000.070	022443356
500 µL Blue control button	3112 000.088	022443402
1000 µL Blue control button	3112 000.096	022443453
1 Piston holder (5 pcs.)	3111 609.003	022476211
2 Pistons		
2 - 20 µL	3110 818.008	022476271
10 - 100 µL	3110 813.006	022476289
100 - 1000 µL	3110 815.009	022476327
4 Stroke spring		
10 - 100 µL	3111 607.000	022476378
200 - 1000 µL	3111 608.007	022476394
6 Screw	not sold separately	not sold separately
7 Spring	not sold separately	not sold separately
8 Seal		
10 - 100 µL, incl. (6), (7)	4910 820.007	022475282
100 - 1000 µL, incl. (6), (7)	3110 845.005	022476467
10 Pipette lower part		
2 - 20 µL, incl. seal	3110 858.000	022476670
10 - 100 µL, incl. (6), (7), (8), (13)	3110 859.006	022476696
100 - 1000 µL, incl. (6), (7), (8)	3110 855.000	022476726

	Order number International	Order number North America
12 Ejection sleeve		
10 - 100 μ L	3110 861.000	022476491
200 - 1000 μ L	3110 865.006	022476521
13 Filling tube (5 pcs., 1 wire punch)	3110 872.002	022476556
Wrench	3111 501.016	022476581

II. Adjustable-volume pipettes

Pipettes / spare parts	Order number International	Order number North America
Models		
0.1 - 2.5 μ L Dark gray control button	3111 000.114	022471856
0.5 - 10 μ L Light gray control button	3111 000.122	022471902
2 - 20 μ L Yellow control button	3111 000.130	022471953
10 - 100 μ L Yellow control button	3111 000.149	022472003
20 - 200 μ L Yellow control button	3111 000.157	022472054
100 - 1000 μ L Blue control button	3111 000.165	022472101
500 - 5000 μ L Violet control button	3111 000.173	022472151
1 - 10 mL Turquoise control button	3111 000.181	022472208
1 Piston holder (5 pcs.)	3111 609.003	022476211
2 Piston rod		
500 - 5000 μ L	3110 806.000	022476360
1 - 10 mL	3110 806.000	022476360
3 Pistons		
0.1 - 2.5 μ L	3110 810.007	022476220
0.5 - 10 μ L	3110 817.001	022476254
2 - 20 μ L	3110 818.008	022476271
10 - 100 μ L	3110 813.006	022476289
20 - 200 μ L	3110 814.002	022476301
100 - 1000 μ L	3110 815.009	022476327
500 - 5000 μ L	3110 816.005	022476343
1 - 10 mL	3111 601.002	022476351
4 Stroke spring		
0.1 - 2.5 μ L	3111 607.000	022476378
0.5 - 10 μ L	3111 607.000	022476378
2 - 20 μ L	3111 607.000	022476378
10 - 100 μ L	3111 607.000	022476378
20 - 200 μ L	3111 608.007	022476378
100 - 1000 μ L	3111 608.007	022476394
500 - 5000 μ L	3110 826.000	022476408
1 - 10 mL	3110 826.000	022476408

Research - Part B - Ordering information

	Order number International	Order number North America
5 Cylinder attachment		
500 - 5000 μ L	3110 836.006	022476424
1 - 10 mL	3111 602.009	022476416
6 Locking mechanism (for 10 mL only)	3111 604.001	
7 Screw	not sold separately	not sold separately
8 Spring	not sold separately	not sold separately
9 Seal		
10 - 100 μ L, incl. (6), (7)	4910 820.007	022475282
20 - 200 μ L, incl. (6), (7), (9), centering aid	3110 844.009	022476441
100 - 1000 μ L, incl. (6), (7)	3110 845.005	022476467
10 Press piece	not sold separately	not sold separately
11 Pipette lower part		
0.1 - 2.5 μ L, incl. seal	3110 850.009	022476629
0.5 - 10 μ L, incl. seal	3110 857.003	022476653
2 - 20 μ L, incl. seal	3110 858.000	022476670
10 - 100 μ L, incl. (6), (7), (8), (13)	3110 859.006	022476696
20 - 200 μ L, incl. (6), (7), (8), (9), (13)	3110 849.000	022476700
100 - 1000 μ L, incl. (6), (7), (8)	3110 855.000	022476726
500 - 5000 μ L, incl. (2), (3), (4), (5), (11)	3110 856.007	022476742
1 - 10 mL, incl. (2), (3), (4), (5), (5a), (11)	3111 603.005	022476114
12 Cylinder	not sold separately	not sold separately
13 Ejection sleeve		
0.1 - 2.5 μ L	3110 860.004	022476483
0.5 - 10 μ L	3110 861.000	022476491
2 - 20 μ L	3110 861.000	022476491
10 - 100 μ L	3110 861.000	022476491
20 - 200 μ L	3110 863.003	022476505
100 - 1000 μ L	3110 865.006	022476521
500 - 5000 μ L	3110 866.002	022476548
Ejector		
1 - 10 mL	3111 605.008	022476611
14 Filling tube (5 pcs., 1 wire punch)		
10 - 100 μ L	3110 872.002	022476556
20 - 200 μ L	3110 873.009	022476564
15 Filter for 10 mL pipette (50 pcs., in bag)	3111 606.004	022472305
Wrench	3111 501.016	022476581
Disassembly aid (for 500 - 5000 μ L and 1 - 10 mL)	3110 110.021	022476602

III. Multi-channel pipettes

Pipettes/spare parts	Order number International	Order number North America
8-channel:		
0.5 - 10 μ L Light gray control button	3114 000.115	022452002
10 - 100 μ L Yellow control button	3114 000.131	022452029
30 - 300 μ L Orange control button	3114 000.158	022452045
12-channel:		
0.5 - 10 μ L Light gray control button	3114 000.123	022452061
10 - 100 μ L Yellow control button	3114 000.140	022452088
30 - 300 μ L Orange control button	3114 000.166	022452100
Lower part, 8-channel:		
0.5 - 10 μ L, cpl.	3114 608.008	022453882
10 - 100 μ L, cpl.	3114 610.002	022453904
30 - 300 μ L, cpl.	3114 612.005	022453921
12-channel:		
0.5 - 10 μ L, cpl.	3114 609.004	022453947
10 - 100 μ L, cpl.	3114 611.009	022453963
30 - 300 μ L, cpl.	3114 613.001	022453980
Tool		
0.5 - 10 μ L, cpl.	4908 829.005	022456890
10 - 100 μ L, cpl.	4860 735.003	022467034
30 - 300 μ L, cpl.	4908 832.006	022456911
1 set of O-rings for nose cones, incl. assembly aid for 100 and 300 μ L	4908 836.001	022456351
Set of piston seals (see page 115 of this manual; set of piston seals contains further: press piece, spring, spring plate)		
0.5 - 10 μ L, cpl.	4908 833.002	022456539
10 - 100 μ L, cpl.	4860 721.002	022467212
30 - 300 μ L, cpl.	4908 835.005	022456555

IIIa. Additional accessories

	Order number International	Order number North America
Silicone grease, 2 g	0013 063.010	022348515
Silicone grease, 60 g		022348501
Reagent reservoir "Tip-Tub", autoclavable multi-channel for reagent vessel, set (10 tubs + 10 lids)	0030 058.607	022265806
Instruction manual	3111 900.115	
CASO II (Pipette Calibration Software)	3113 004.001	
CASO accessories see eppendorf catalog		
Calibration seal, red (5 pcs.)	3111 610.001	

IV. Pipette holder

	Order number International	Order number North America
Adapter only for Pipette carousel 4807 (old)		
Adapter for Research variable 500-5000 µL	3110 112.008	022472178
Adapter for Research Multi-channel pipettes	3114 607.001	022455311
Pipette carousel 3115		
Pipette carousel, incl. 6 pipette supports	3115 000.003	022444905
Pipette holder (replacement for stand)	3115 600.019	022260588
Pipette holder (with adhesive surface for attachment to lab benches and wall)	3115 000.020	022444913

V. Pipette tips

TipT.I.P.S. (The packaging units stated represent the minimum ordering quantity).

	Color code	Order number International	Order number North America
Standard			
in bags			
10 x 500 = 1000 tips			
0.1 - 10 µL	dark gray*	0030 000.811	022492004
0.1 - 20 µL	medium gray**	0030 000.838	022492012
0.5 - 20 µL L	light gray	0030 000.854	022492021
2 - 200 µL	yellow	0030 000.870	022492039
20 - 300 µL	orange	0030 000.897	022492047
50 - 1000 µL	blue	0030 000.919	022492055
100 - 5000 µL	violet	0030 000.978	022492080
500 tips)			

* former name: anthracite
** former name: dark gray

Research - Part B - Ordering information

	Color code	Order number International	Order number North America
1 - 10 mL standard (200 tips)	turquoise	0030 000.765	022492098
1 - 10 mL long (200 Tips)	turquoise	0030 000.781	022492101
Set			
1 Box incl. 5 x 96 tips			
0.1 - 10 µL	dark gray*	0030 073.207	022491407
0.1 - 20 µL	medium gray**	0030 073.223	022491415
0.5 - 20 µL L	light gray	0030 073.240	022491423
2 - 200 µL	yellow	0030 073.266	022491431
20 - 300 µL	orange	0030 073.282	022491440
50 - 1000 µL	blue	0030 073.304	022491458
Reloads			
10 x 96 = 960 tips			
0.1 - 10 µL (in stacks)	dark gray*	0030 073.363	022491504
0.1 - 20 µL	medium gray**	0030 073.380	022491512
0.5 - 20 µL L	light gray	0030 073.401	022491521
2 - 200 µL (in stacks)	yellow	0030 073.428	022491539
20 - 300 µL	orange	0030 073.444	022491547
50 - 1000 µL	blue	0030 073.460	022491555
Reloads PCR-clean			
10 x 96 = 960 tips			
0.1 - 10 µL (in stacks)	dark gray*	0030 073.746	022491709
0.1 - 20 µL	medium gray**	0030 073.762	022491717
0.5 - 20 µL L	light gray	0030 073.789	022491725
2 - 200 µL (in stacks)	yellow	0030 073.800	022491733
20 - 300 µL	orange	0030 073.827	022491741
50 - 1000 µL	blue	0030 073.843	022491750
Box			
1 box plus 96 tips			
0.1 - 10 µL	dark gray*	0030 073.002	022491300
0.1 - 20 µL	medium gray**	0030 073.029	022491318
0.5 - 20 µL L	light gray	0030 073.045	022491326
2 - 200 µL	yellow	0030 073.061	022491334
20 - 300 µL	orange	0030 073.088	022491342
50 - 1000 µL	blue	0030 073.100	022491351
100 - 5000 µL (24 tips)	violet	0030 073.169	022491385

* former name: anthracite

** former name: dark gray

	Color code	Order number International	Order number North America
Racks			
plus 10 x 96 = 960 tips			
0.1 - 10 µL	dark gray*		022491903
0.1 - 20 µL	medium gray**		022491911
0.5 - 20 µL L	light gray		022491920
2 - 200 µL	yellow		022491938
20 - 300 µL	orange		022491946
50 - 1000 µL	blue		022491954
500 - 5000 µL (120 tips)	violet		022491989
Racks PCR-clean			
plus 10 x 96 = 960 tips			
0.1 - 10 µL	dark gray*		022491806
0.1 - 20 µL	medium gray**		022491814
0.5 - 20 µL L	light gray		022491822
2 - 200 µL	yellow		022491831
20 - 300 µL	orange		022491849
50 - 1000 µL	blue		022491857
500 - 5000 µL (120 tips)	violet		022491881
Racks			
sterile, plus 10 x 96 = 960 tips			
0.1 - 20 µL	medium gray**		022492250
2 - 200 µL	yellow		022492276
20 - 300 µL	orange		022492284
50 - 1000 µL	blue		022492292
100 - 5000 µL (240 tips)	violet		022492314
Racks Eppendorf Biopur			
colorless, sterile, pyrogen-free DNA-free, RNase-free, ATP-free			
5 x 96 = 480 tips			
0.1 - 20 µL	medium gray**	0030 075.005	022491067
2 - 200 µL	yellow	0030 075.021	022491083
20 - 300 µL	orange	0030 075.048	022491091
50 - 1000 µL	blue	0030 075.064	022491105
1 - 10 mL	turquoise	0030 075.145	022491164
standard (120 tips)			
Singles (Eppendorf Biopur) individually wrapped			
100 tips			
0.1 - 20 µL	medium gray**	0030 010.019	022491130
2 - 200 µL	yellow	0030 010.035	022491148
50 - 1000 µL	blue	0030 010.051	022491158

* former name: anthracite

** former name: dark gray

	Color code	Order number International	Order number North America
ep Dualfilter T.I.P.S.			
PCR-clean, sterile			
in racks			
10 x 96 = 960 tips			
0.1 - 10 µL S	dark gray	0030 077.504	022491202
0.1 - 10 µL M	medium gray**	0030 077.512	022491211
0.5 - 10 µL L	light gray	0030 077.520	022491229
2 - 20 µL	yellow	0030 077.539	022491270
2 - 100 µL	yellow	0030 077.547	022491237
2 - 200 µL	yellow	0030 077.555	022491296
20 - 300 µL	orange	0030 077.563	022491245
50 - 1000 µL	blue	0030 077.571	022491253
100 - 5000 µL	violet	0030 077.580	022491261
5 x 24 = 120 tips			
1 - 10 mL	turquoise	0030 077.598	022491288
long (100 pcs.)			
individually blister-packed			
GELoader® tips			
(f. 0.5 - 10 µL)			
1 set = 200 tips	light gray	0030 001.222	022351656

* former name: anthracite

** former name: dark gray

	Color code	Order number International	Order number North America
epT.I.P.S. LoRetention Dualfilter, PCR clean,			
sterile and pyrogen free, in racks,			
10 x 96 = 960 tips			
0.1 - 10 µL S Dualfilter	dark gray	0030 077.610	022493000
0.5 - 20 µL L Dualfilter	light gray	0030 077.628	022493002
20 - 300 µL Dualfilter	orange	0030 077.636	022493004
2 - 100 µL Dualfilter	yellow	0030 077.644	022493006
50 - 1000 µL Dualfilter	blue	0030 077.652	022493008
Reloads, LoRetention PCR clean,			
10 x 96 = 960 tips			
0.1 - 10 µL Reload	dark gray	0030 072.006	022493010
0.5 - 20 µL L Reload	light gray	0030 072.014	022493012
2 - 200 µL Reload	yellow	0030 072.022	022493014
50 - 1000 µL Reload	blue	0030 072.030	022493016
Reloads, LoRetention, autoclavable,			
10 x 96 = 960 tips			
0.1 - 10 µL Reload	dark gray	0030 072.049	022493018
0.5 - 20 µL L Reload	light gray	0030 072.057	022493020
2 - 200 µL Reload	yellow	0030 072.065	022493022
50 - 1000 µL Reload	blue	0030 072.073	022493024
Racks, LoRetention PCR clean,			
10 x 96 = 960 tips			
0.1 - 10 µL Rack	dark gray		022493026
0.5 - 20 µL L Rack	light gray		022493028
2 - 200 µL Rack	yellow		022493030
50 - 1000 µL Rack	blue		022493032